



Impact S[®]

Compact Scale

User's Guide

©2013 Mettler-Toledo, LLC

No part of this manual may be reproduced or transmitted in any form or by any means, electronic or mechanical, including photocopying and recording, for any purpose without the express written permission of Mettler-Toledo, LLC.

U.S. Government Restricted Rights: This documentation is furnished with Restricted Rights.

Publication Revision History

Part Number	Date	Revisions
64065336 P01	12/08	New manual
64065336 P02	01/09	New GUI added throughout
64065336 P03	03/09	Final revision 1 complete
64065336 R00	05/09	Chapter 4 modified, Chapter 6 tables reworked
64065336 R01	12/10	Formatting, text style changes, corrected capacity specs in Chap 1.
64065336 R02	09/11	Updates to all chapters to include latest hardware for SBC and application software.
64065336 R03	5/12	Updated warnings to ANSI std. Updates for 1.3.6 software. LLC name change.
64065336 R04	8/12	Updates to Chapter 2, OPER button section, and details updates throughout Chapter 2 and Chapter 3 including updates for 1.3.7 NF and others. Updates to Chapter 4 label loading.
64065336 R05	6/13	Added FCC Notice section.
64065336 R06	10/13	Updated Wifi Communication section

Trademarks

METTLER TOLEDO® and Impact S® are registered trademarks of Mettler-Toledo, LLC, Columbus, OH, USA.

FCC Notice

This device complies with Part 15 of the FCC Rules and the Radio Interference Requirements of the Canadian Department of Communications. Operation is subject to the following conditions: (1) this device may not cause harmful interference, and (2) this device must accept any interference received, including interference that may cause undesired operation.

This equipment has been tested and found to comply with the limits for a Class A digital device, pursuant to Part 15 of FCC Rules. These limits are designed to provide reasonable protection against harmful interference when the equipment is operated in a commercial environment. This equipment generates, uses, and can radiate radio frequency energy and, if not installed and used in accordance with the instruction manual, may cause harmful interference to radio communications. Operation of this equipment in a residential area is likely to cause harmful interference in which case the user will be required to correct the interference at their own expense.

Precautions

READ this manual BEFORE operating or servicing this equipment.

FOLLOW these instructions carefully.

SAVE this manual for future reference.

DO NOT allow untrained personnel to operate, clean, inspect, maintain, service, or tamper with this equipment.

ALWAYS DISCONNECT this equipment from the power source before cleaning or performing maintenance.

CALL METTLER TOLEDO® for parts, information, and service.

METTLER TOLEDO® reserves the right to make refinements or changes without notice.

	NOTICE
	TO PREVENT EQUIPMENT DAMAGE Read and understand the operators manual before using the equipment. Failure to follow operating instructions could result in equipment damage.

	WARNING
	ELECTRICAL SHOCK HAZARD Only permit qualified personnel to service this equipment. Exercise care when making checks, tests and adjustments that must be made with power on.

	WARNING
	ELECTRICAL SHOCK HAZARD Connect to a properly grounded outlet only. Do not remove the ground prong. Power outlets must be easily accessible and located no further than the length of the power cord supplied with the product.

	WARNING
	ELECTRICAL SHOCK HAZARD Disconnect and lock out all power to this unit before removing or installing the fuse, cleaning, or servicing.

	NOTICE
	ELECTROSTATIC SENSITIVE DEVICES Observe precautions for handling electrostatic sensitive devices.

	NOTICE
	EQUIPMENT DAMAGE Disconnect power before connecting or disconnecting any internal electronic components or interconnecting wiring between electronic equipment.

Contents

1	Introduction	1-1
	General	1-1
	Specifications	1-2
	Power Switch	1-3
	Network Connection.....	1-3
	Leveling the Scale.....	1-4
2	Operating Instructions	2-1
	Operator Controls.....	2-1
	Keypad	2-1
	Operator Display	2-2
	Button Styles.....	2-3
	Customer Display.....	2-4
	PLU Screens	2-5
	PLU Screen Details	2-6
	Calling PLUs	2-7
	Printing Labels.....	2-8
	By Weight PLU.....	2-8
	By Count PLU	2-8
	Standard Pack PLU.....	2-9
	Temporary Overrides	2-9
	OPER Button.....	2-10
	Operations Menu from Home Screen	2-10
	Operator Menu from Transaction Screen	2-29
	Memory Mode.....	2-30
3	Setup Mode	3-1
	Introduction	3-1
	Database	3-2
	PLUs	3-3
	Extra Text.....	3-7
	Nutrifacts.....	3-7
	COOL.....	3-12
	Accumulators.....	3-21
	Clear	3-22
	Reports	3-23
	Action Code Text	3-23
	Department Settings.....	3-25
	Grade	3-26
	Group.....	3-26
	Preset.....	3-27
	Quick Edits.....	3-28
	Labels	3-30
	Label Group.....	3-30

	Label Formats	3-31
	Print Test Label	3-32
	Verify Labels	3-32
	Char. Wrap	3-33
	Orientation.....	3-33
	Unit Setup.....	3-34
	Time and Date	3-34
	Language.....	3-35
	Backup/Restore.....	3-36
	Scale Settings	3-42
	Communication	3-53
	Screen Calibration	3-61
	Set Home Screen.....	3-62
	Technician.....	3-62
	Select Department	3-62
	Printer Setup.....	3-63
	Label Group.....	3-64
	Print Speed.....	3-64
	Calibrate Gap Sensor	3-64
	Calibrate Take Label Sensor	3-64
	Label Delivery	3-65
	Graphic Format.....	3-65
	Auto Size	3-65
	Label Taken	3-65
	Label Length, Gap Length, Image Offset, Eject Length.....	3-65
	Measure Label	3-66
	Printer Contrast	3-66
	Security	3-66
	Users.....	3-67
	System Status	3-68
	System Information.....	3-68
	Log View.....	3-68
	Log Level	3-70
	Marquee	3-70
	Setup.....	3-71
	Import Image	3-72
	Timer.....	3-73
4	Labels	4-1
	Loading Labels	4-1
	Label Requirements.....	4-2
	Label Paper	4-2
	Label Stripping.....	4-3
	Finished Label Roll Requirements	4-3
	Finished Label and Roll Dimensional Requirements	4-5
	Preprinted Labels	4-7
	Special Shaped Labels.....	4-8
	Optical Densities.....	4-9
	Black Stripe Optical Density	4-9
5	Maintenance	5-1
	External Cleaning.....	5-1

Printer Cleaning5-2

6 Appendix 6-1

- Geo Index6-1**
- Country Currency Defaults6-3**
- Country Time Defaults6-4**
- Misc. Country Defaults.....6-5**

METTLER TOLEDO

For your notes

1

Introduction

General

Thank you for purchasing an Impact S[®] scale. Because Mettler Toledo designed the Impact series for your current and future requirements, the Impact S[®] can handle a variety of operations and easily adapts to changing process and data requirements. This flexibility protects your investment and helps you keep pace with rapidly changing production and customer demands.



Impact S Scale

The METTLER TOLEDO[®] Impact S[®] scale offers very easy programming with a user friendly interface. All scales contain a built-in thermal label printer which is designed for quick and easy roll changes. The Impact S[®] touchscreen preset keys provide quick and easy PLU look-up.

The standard Impact S[®] has an internal loadcell and customer rear display. A dead-deck version is also available for label printing and will connect to an external scale base for weight input if required.



Impact S Dead-Deck

Specifications

Description	Specifications – Impact S
Capacity x Division	30 x 0.01 lb 15 x 0.005 kg 6/15 x 0.002/0.005 kg 15/30 x 0.005/0.01 lb
Weighing Modes	lb , kg, (single and dual interval)
Dimensions	H: 5.875", W: 15.35", D: 17.5"
Platter Dimension	W: 15.25" x D: 9.25" (10.0" counting lip)
Weight of Unit	23.5 lb (10.7 kg)
Shipping Weight	30.0 lb (13.7 kg)
Base Construction	Plastic upper shell with cast-metal bottom
Operator Display	5.7" backlit Monochrome QVGA display with tactile keypad
Operator Keyboard / Touchscreen	4 wire resistive Touchscreen
Customer Display	Monochrome 240 x 240 LCD
Printer	3" (72 mm paper, 80mm path), up to 5"/sec, thermal - 6" roll capacity
Power	100-240 VAC, 50/60 Hz, 0.5A
Operating Temperature	0° C to 40° C, humidity 5% to 95% non-condensing
Storage Temperature	-20° C to 70° C with humidity from 5% to 95% non -condensing
Network Interface	Ethernet 802-3 10/100 RF optional 802.11B/G
Processor	XSCALE
Memory	Minimum 64 Megabyte SDRAM
Mass Storage	Minimum 512 MB Compact Flash
Available Serial port	External load cell
RJ13	External load cell power
USB Port	For mouse, keyboard, USB flash drive, etc.

Power Switch

The power switch and power cord jack are located under the touchscreen on the left front of the scale.

Press **O** on the switch to turn the scale power to ON and again to turn the scale off (it is a momentary switch, and will not stay depressed). Always exit any editing screens before pressing the switch to turn power OFF. Always turn the scale off before cleaning.

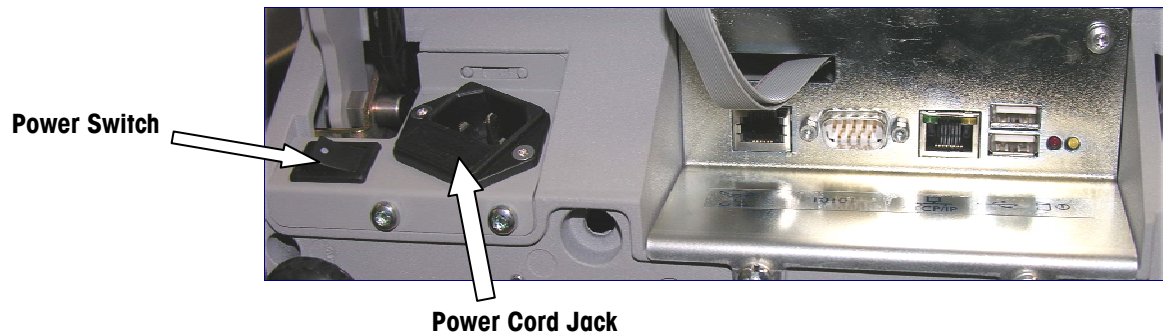

Network Connection

The Impact S[®] can connect to your Ethernet network using a cable or optional wireless radio. If you use a wired network connection and experience network connection problems, check the Ethernet cable to make sure it is connected and seated securely in the jack, located under the touchscreen at the front of the scale.

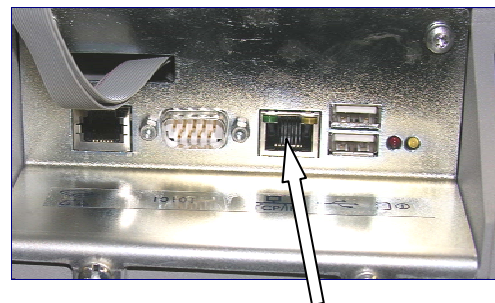

Ethernet port

If the scale has a wireless card installed, do not connect an external Ethernet cable to the Ethernet port.

Leveling the Scale

The Impact S® scale must be level and installed on a stable counter. The level indicator is located behind the customer display, as shown below.

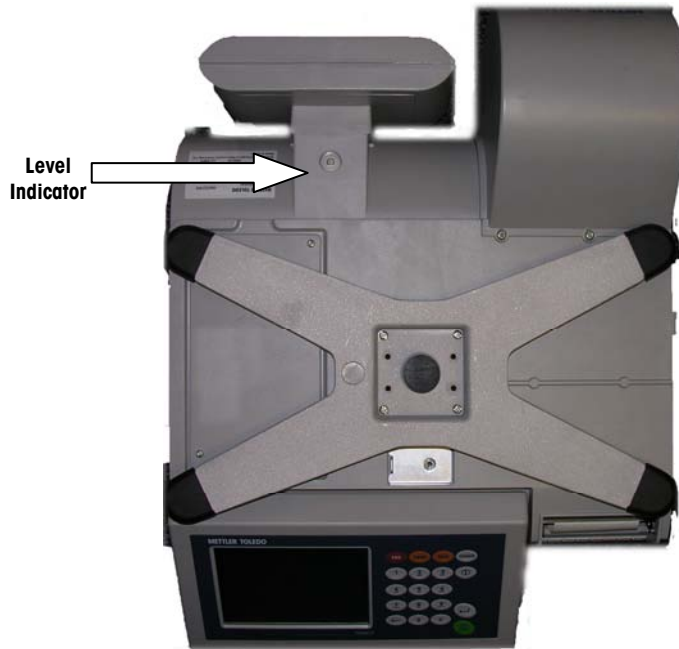

Level Indicator Location

The bubble in the indicator must be centered inside the circle. If the bubble is outside of the circle on the indicator, use the four leveling feet to level the scale.

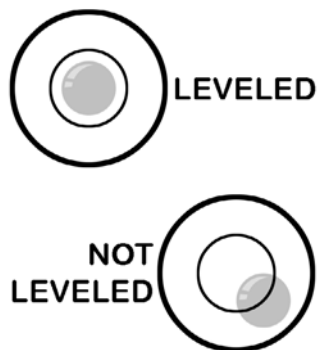

The level indicator consists of a bubble and two circles. Center the bubble and the scale will be level.

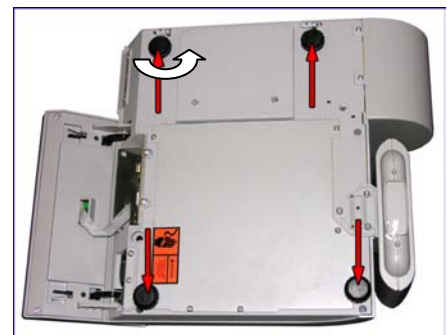

Rotate leveling feet clockwise or counterclockwise to determine a level platter.

2

Operating Instructions

Operator Controls

The main operator screen of the Impact S[®] consists of a keypad and touchscreen display screen. The screen will change based on what transaction is taking place.

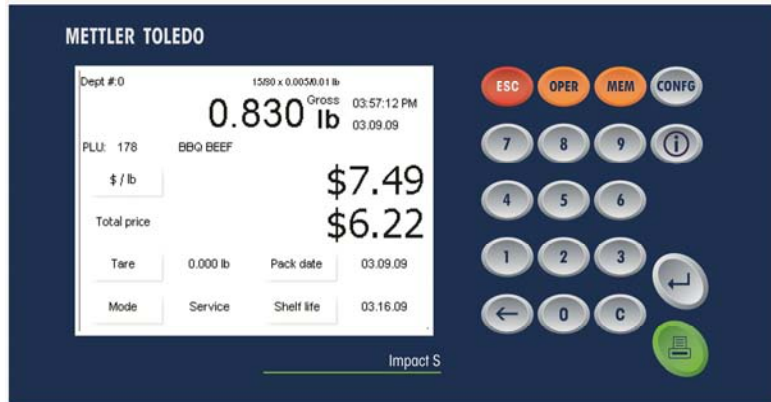

Keypad

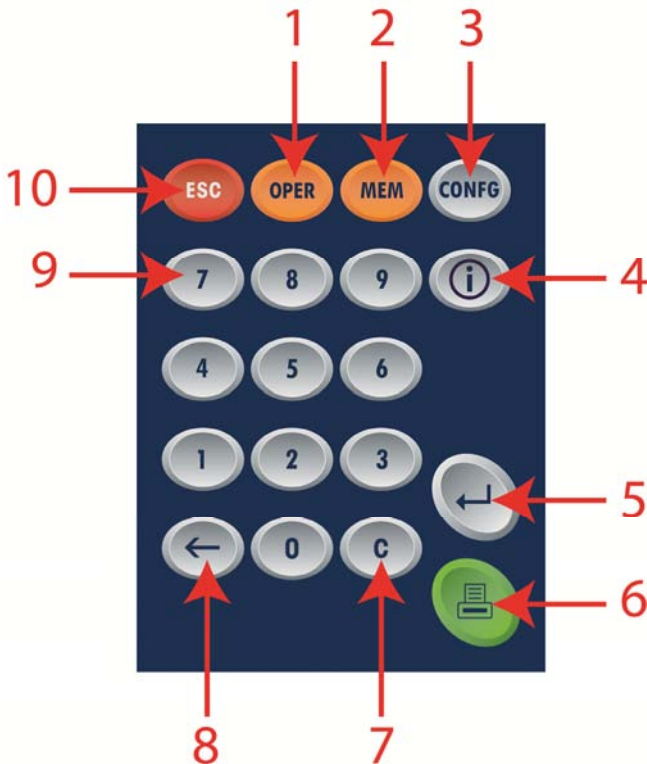

Keypad Components	
1	OPER – Operator Key. Provides an operator menu from the home screen for overrides. Also allows edits to be made to the PLU by the Operator for the current transaction ONLY.
2	MEM – Memory Mode Key. Places a transaction in Memory Mode which collects multiple transactions and prints them on one label.
3	CONFIG – Configuration key. Access to the Configuration screen allowing scale setup.
4	Help key (i). Activates the help system specific to the displayed screen (if applicable).
5	Enter Key. Accepts changes and returns to the previous screen.
6	Print Key. Prints the label (if applicable)
7	C – Clear Key. Clears all data in the entry field.
8	Backspace Key. Used to erase digit to the left of the cursor.
9	Number Keypad. Used to enter PLU and other data.
10	ESC – Escape Key. Quits and returns to the previous screen without saving changes

Operator Display



NOTE: The operator display is a touchscreen. Only use fingertips to press on the keys. DO NOT use any sharp objects on the touchscreen. This could cause permanent damage to the touchscreen.

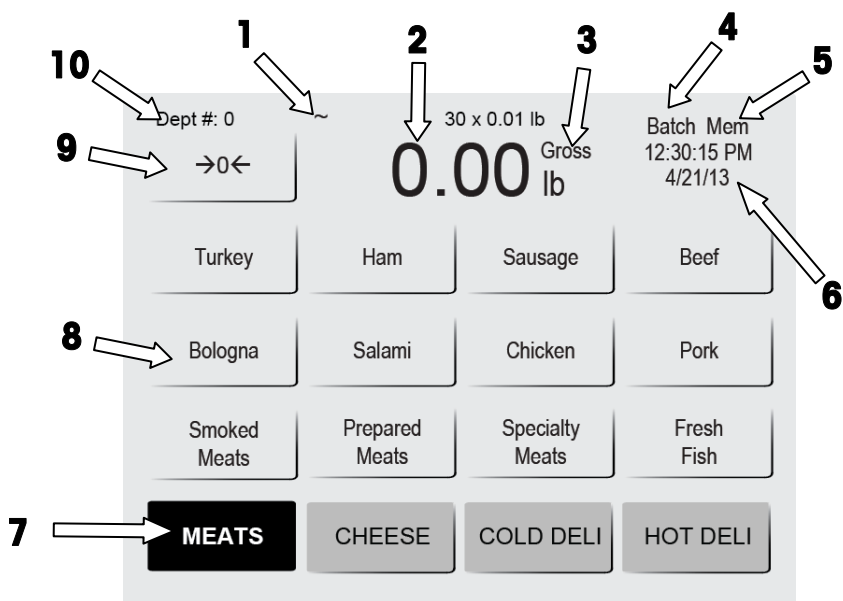

Operator Main Screen Components	
1	Motion/No motion. This symbol indicates that the weight on the scale is fluctuating; when no symbol appears the weight on the scale is stable.
2	Weight Display shows the current weight on the scale as well as the unit of measure (kg/lb).
3	Net/Gross when NET displays, it indicates a tare weight has been taken.
4	Batch is used to print multiple labels in one batch. When in this mode, if any transactions are in queue, the word 'Batch' will appear.
5	Memory (MEM) is used to store transactions for use in printing a receipt-type label. When transactions are in memory, the word MEM will appear.
6	Date and Time. Shows current date and time. The display format can be set from Configuration.
7	Preset Page Buttons. Select the preset Page you wish to use.
8	Preset Keys. Used for one-touch calling of PLU records or, if the key is linked to another page, touching will display that page.
9	Touch to Zero. Zeros out the scale.
10	Current Department



Note: When the scale is operating in Client mode, the display will show Online 1 or Offline 1 indicating whether or not this client is connected to the STEM master.

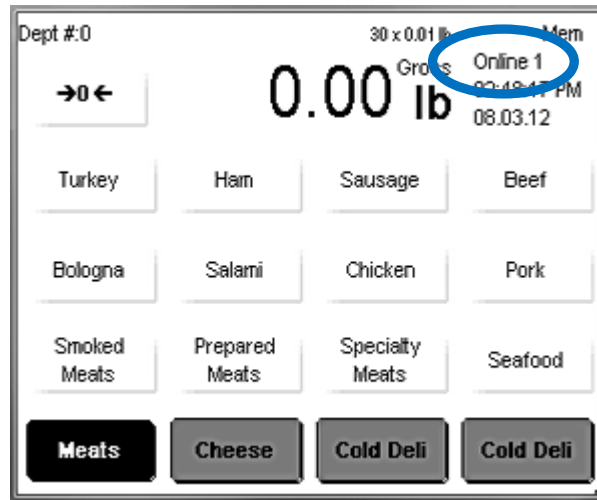

**Main Screen
(Client Mode)**

Button Styles

The button style is selectable from the OPER menu under Operator Display. There are two styles available.



Button Style 1 (default)

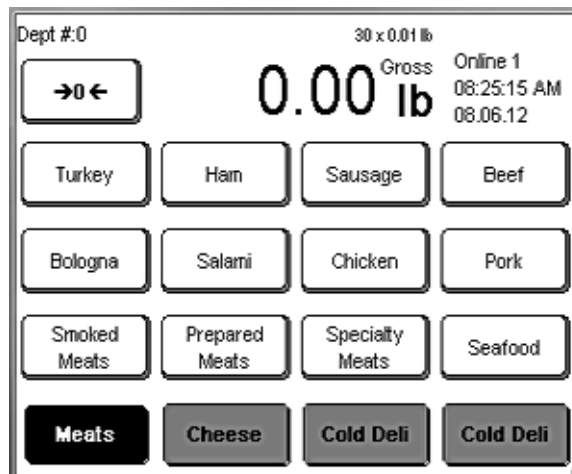

Button Style 2

Customer Display

The Customer Display can show different display screens based on the operation mode the scale is in. The different options are **By Weight PLU**, **By Count PLU**, **Standard Pack PLU**, **Weight Displayed/Weight at Zero/No PLU** and **Weight at Zero/No PLU** with a marquee message.



Customer Display – By Count PLU display

PLU Screens

The **PLU screen** will vary based on the type of PLU that is being displayed: **By Weight**, **By Count** or **Standard Pack**.

On the PLU screen, if a value field has a border it can be changed for that transaction. Override the values by touching the box and selecting/entering new values. Note: this is only a temporary override for this transaction only and the values will revert to the original the next time the PLU is called.

If the field has no border the value cannot be changed, as determined by **Setup Configuration**.

By Weight

Dept #:0	30 x 0.01 lb	Mem
	Net	10:59:04 AM
	1.02 lb	07.26.12
PLU: 13	Virginia Baked Ham Low Sodium	
Unit price		\$3.89
Total price		\$3.97
Tare	0.02 lb	Pack date 07.26.12
Mode	Service	Shelf life Blanked

By Count

Dept #:0	30 x 0.01 lb	Mem
→0←	Gross	10:56:34 AM
	0.00 lb	07.26.12
PLU: 291	HOT BARBEQUED	
Unit price		\$3.99
Total price		\$3.99
Quantity	1	Pack date 07.26.12
Total labels	1	Shelf life 07.26.12

Standard Pack

Dept #:0	30 x 0.01 lb	Mem
→0←	Gross	10:57:09 AM
	0.00 lb	07.26.12
PLU: 707	STRAWBERRIES	
Net weight		12.0 oz
Total price		\$2.99
Quantity	12	Pack date 07.26.12
Total labels	1	Shelf life 07.26.12

PLU Screen Details

1	Motion/No motion. When this symbol appears the weight on the scale is fluctuating; when no symbol appears the weight on the scale is stable.
2	Weight Display shows the current weight on the scale as well as the unit of measure (kg/lb). This is used to calculate the Total Price.
3	Net/Gross when NET displays, it indicates a tare weight has been taken.
4	Batch is used to print multiple labels in one batch. When in Batch mode with transactions in queue, the word Batch will appear.
5	Memory (Mem) is used to store transactions for use in printing a receipt-type label. When transactions are in memory, Mem will appear.
6	Date and Time. Shows current date and time. The display format is set by the configuration.
7	Pack Date displays the current date.
8	Shelf Life displays the date programmed into the PLU used for the shelf life of the product. If the field is blanked, the word "Blanked" will display instead of the date.
9	Mode states the mode of Operation: Service, or PrePack.
10	Tare displays the tare value assigned to the PLU transaction.
11	Total Price of the item. If the item is sold by weight, this is the unit price multiplied by the weight of the item. The Total Price is never operator accessible.
12	Unit Price is programmed into the PLU record. If allowed, touch to override. This is used to calculate the Total Price.
13	PLU number and description.
14	Current Dept. Shows the current default department for the database.
15	Quantity shows how many is in the PLU's count.
16	Number of Labels displays how many labels will be printed.
17	Net Weight the weight of actual goods, excluding packing materials. The scale will automatically determine Kg or Lb or Count depending on the PLU item type.

PLU By-Weight

PLU By-Count

PLU Standard Pack

Calling PLUs

The home screen will display the selected page of presets. The presets can call other pages or a PLU number directly. Service Mode is normally the default for operation. After the product has been weighed, a label has been printed, and the item has been removed from the scale, the PLU will clear and the scale will return to the home screen, ready for the next item.



To begin a transaction, place the item on the scale platter (can be done after a PLU is called up).

Call up the PLU (Price Look Up) Record using the Preset button or enter the PLU number directly on the keypad.

Category buttons are along the bottom of the screen and represent PLUs grouped into categories or departments. The current Preset Page shows a black button, along the bottom indicating the current category. Switch Preset Pages by touching the category buttons.

The PLU screen can vary slightly in appearance depending on whether it is By Weight, By Count, or Standard Pack.

Depending on how the scale has been configured, some of the values can be overridden for the current transaction. If allowed fields such as Shelf Life, Tare, etc. can be changed by using a Temporary Override (see this chapter's Temporary Override section for details).

Printing Labels

By Weight PLU



Priced "Per Pound/kilo" - The weight multiplied by the unit price equals the total price of the product.

Priced "Per Fraction of a Pound/100g" (fractional) - The item may also be priced by the fraction of the pound (where legal and desired). Pricing per 1/4 pound and per 1/2 pound are available. Kilos are not interchangeable for pounds in this mode.

"Pounds/kilos for price" - The PLU may be sold with a pounds-for-price (rather than price per pound). For example, "2 pounds for \$1.00" rather than "\$0.50/pound."

Once the **By Weight** PLU has been called up, make any needed changes, and then press the Print button on the keypad to print a label.

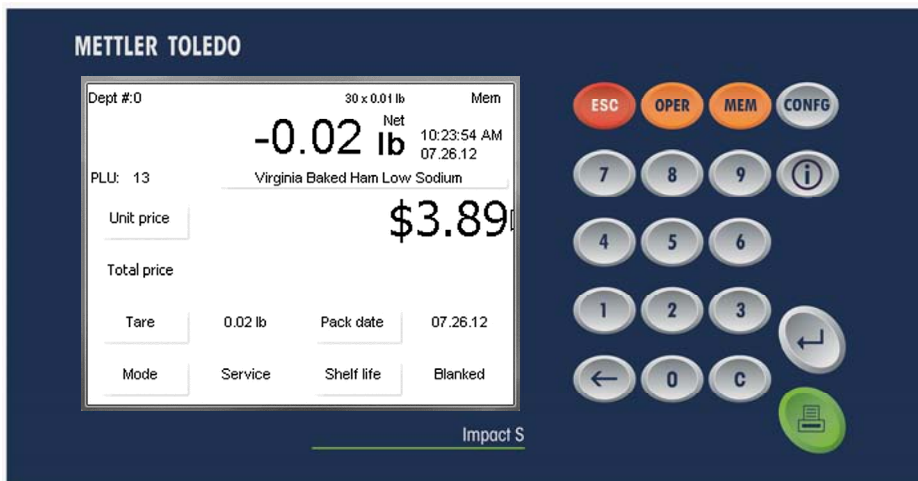

Take the label and remove the item from the scale platter to complete the transaction. The **By Weight** screen may also look different based on if the scale is set up for weighing units in kilograms (kg) or in pounds (lb).

By Count PLU



Examples of items sold by the count are cookies, donuts, rolls, bread, etc. Example: 4 Donuts for \$1.69. The By-Count PLU allows the operator to use the scale to print labels.

Pricing is entered as a certain quantity of items for a set price. If the total weight for the items is needed, a weight field can be configured on the label to print the weight of the items in addition to the By-Count information.

Once the **By Count** PLU has been called up, make any needed changes, and then press the Print button on the keypad to print a label.

If the count is different than what is programmed into the PLU record, press the Quantity button on the screen, enter the new quantity on the keypad, press Enter, and then press the Print key to print the label.

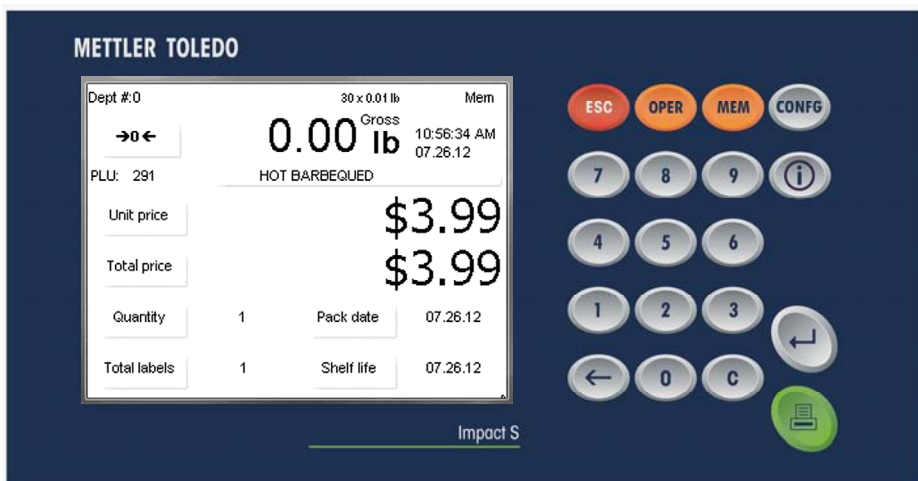

Take the label and remove the item from the scale to complete the transaction.

Standard Pack PLU

When a **Standard Pack** PLU has been called up, make any needed changes, enter the number of labels needed, and then press the Print button on the keypad to print the label(s).

Press the Quantity button on the screen to change the quantity of the item. Enter the new quantity on the keypad, press Enter, and then press the Print key to print the label.



Examples of items sold by Standard Pack include whole chickens, sheet cakes, bread, etc. The Standard Pack PLU is similar to By-Count and also allows the operator to print labels.

These labels indicate the net weight and total price of the item. These types of items all weigh the same (or are assumed to weigh the same or of a minimum value).

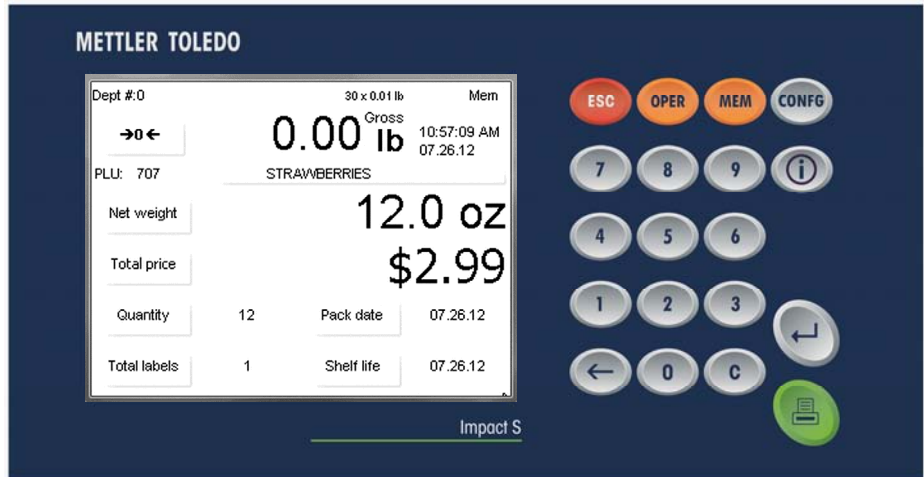

Take the label and remove the item from the scale to complete the transaction.

Temporary Overrides

Some of the values programmed in the PLU can be changed for one transaction (called an Override). The changes are temporary and will not be retained in the original PLU.

If a value can be changed a button outline will appear, indicating the value can be overridden during a transaction.

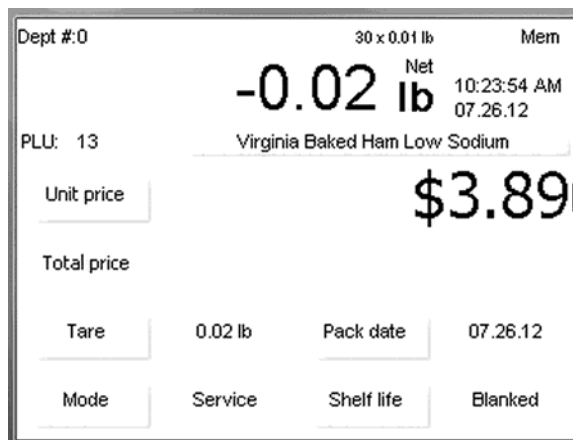

In the PLU screen above, the **Unit Price (\$/lb)**, **Tare**, **Mode**, **Pack Date**, and **Shelf Life**, have buttons outlines, indicating they can be changed. The **Total Price** field does not have a button outline and cannot be overridden.



To change a value, touch the field button. Additional overrides can be found by pressing the OPER button on the keypad.

OPER Button



The OPER button opens the Operations Menu where additional functions for transactions are located. The OPER button will open different sets of functions depending on whether it is pressed from the home screen or a transaction screen and if the scale is operating in Client or Standalone mode.

Operations Menu from Home Screen

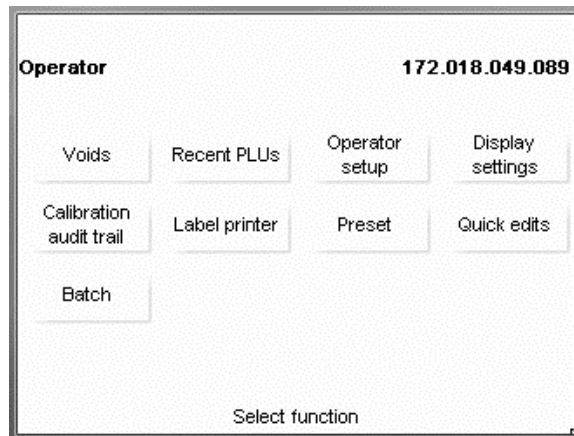

**Operations Menu from Home Screen
(Standalone Mode)**

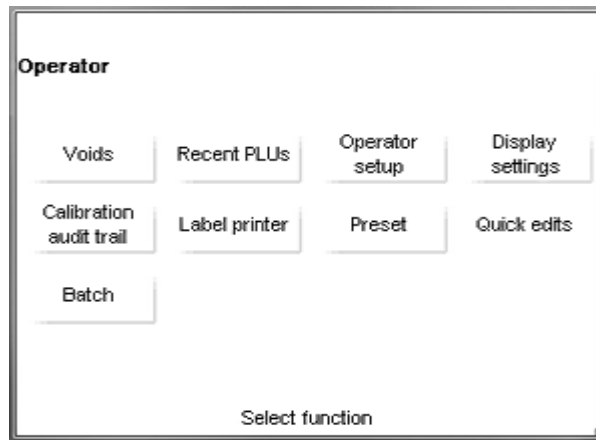

**Operations Menu from Home Screen
(Client Mode)**

Voids

To void a previous transaction so it will not be recorded in the totals data, press the Voids button. The screen will show a list of previous transactions. Touch the line of the transaction to void, and then press the "C" button on the keypad. Press ESC to return to the home screen.

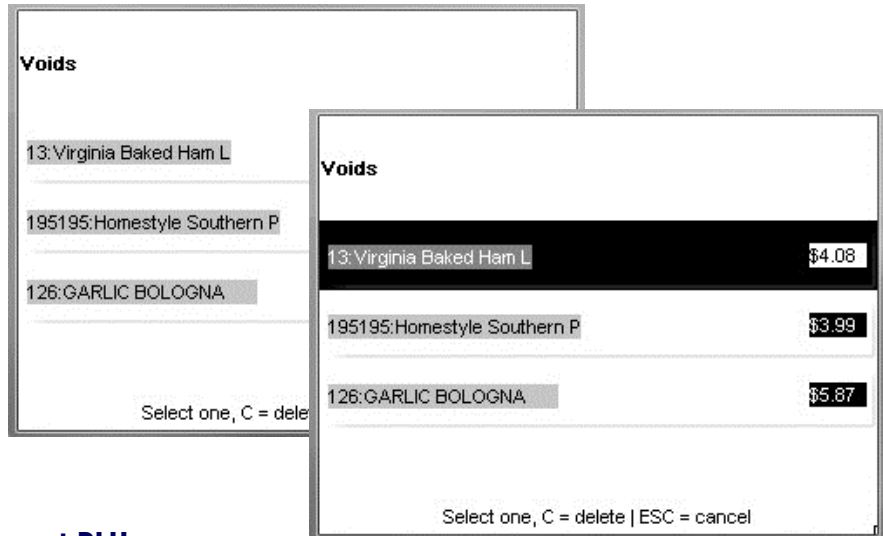

Recent PLUs

Recent PLUs will display a list of recently used PLUs. To call the PLU, touch the line on the touchscreen and the PLU will open for a new transaction.

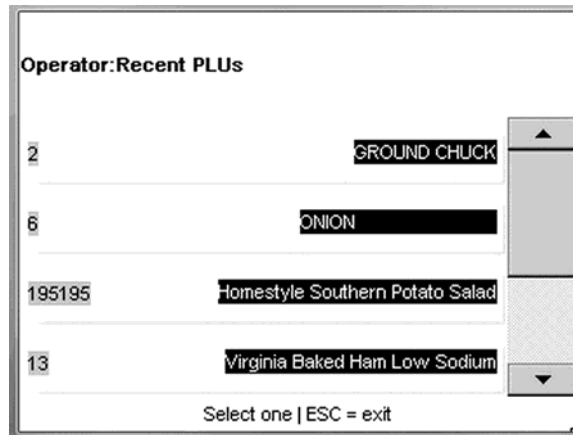

Operator Setup

The scale operator can make selected changes to the configuration of the Impact S.

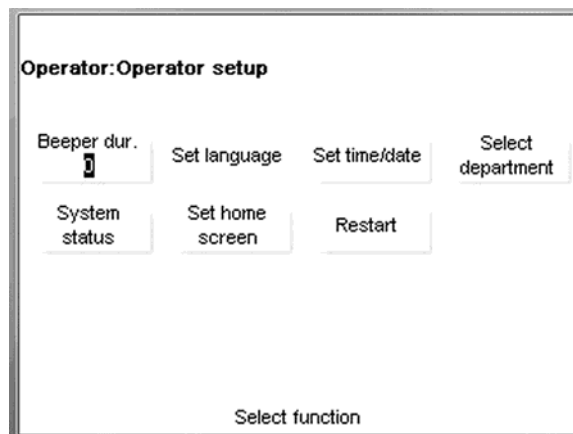

Beeper Duration

Select from Disabled, 1, 2, 3, 4, or 5 for the beeper duration. (1=shortest, 5=longest).

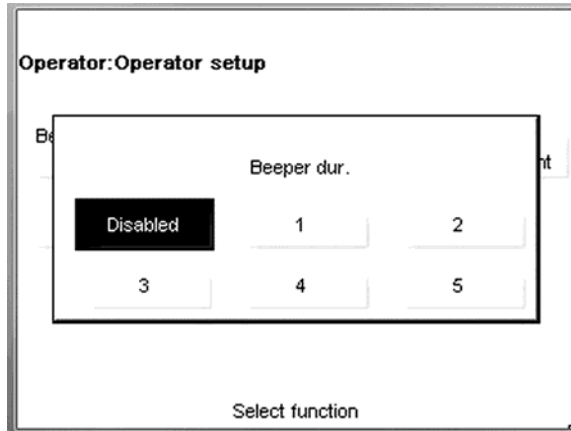

Set Language

Select the default language, English, Spanish, or French.

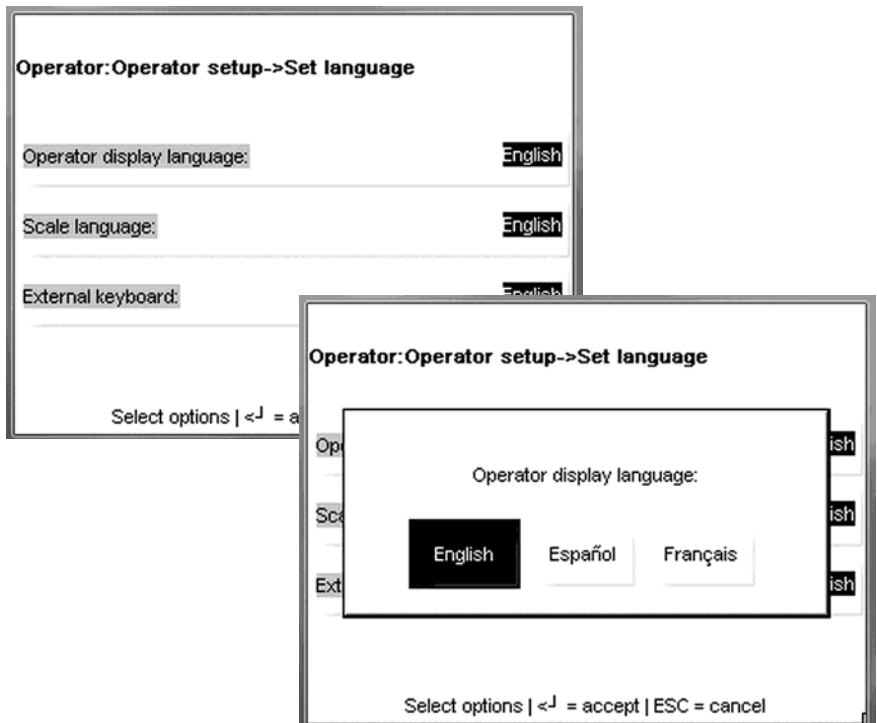

Set Time/Date

Set the time and date. The time and date are used when printing and computing shelf life and for totals reporting.

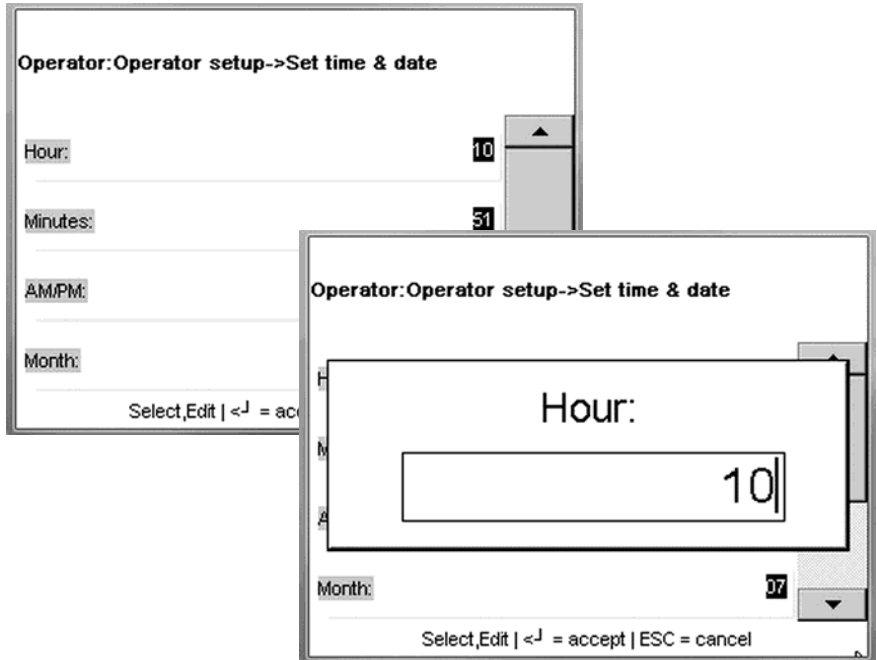

Select Department

Set the default department that the scale will be used in.

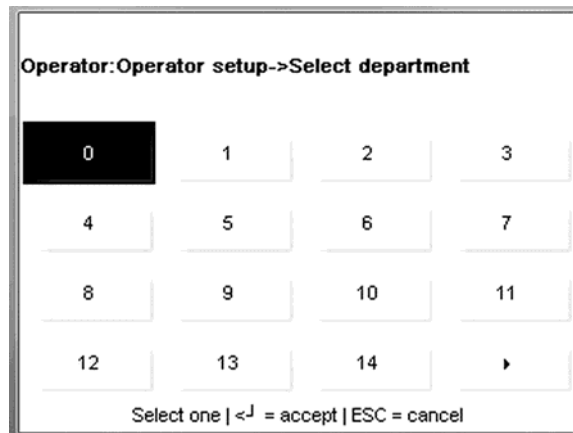

System Status

System status can be used to view status of the scale such as number of PLU, ET, NF, and graphics records, the IP address on the network, and more.

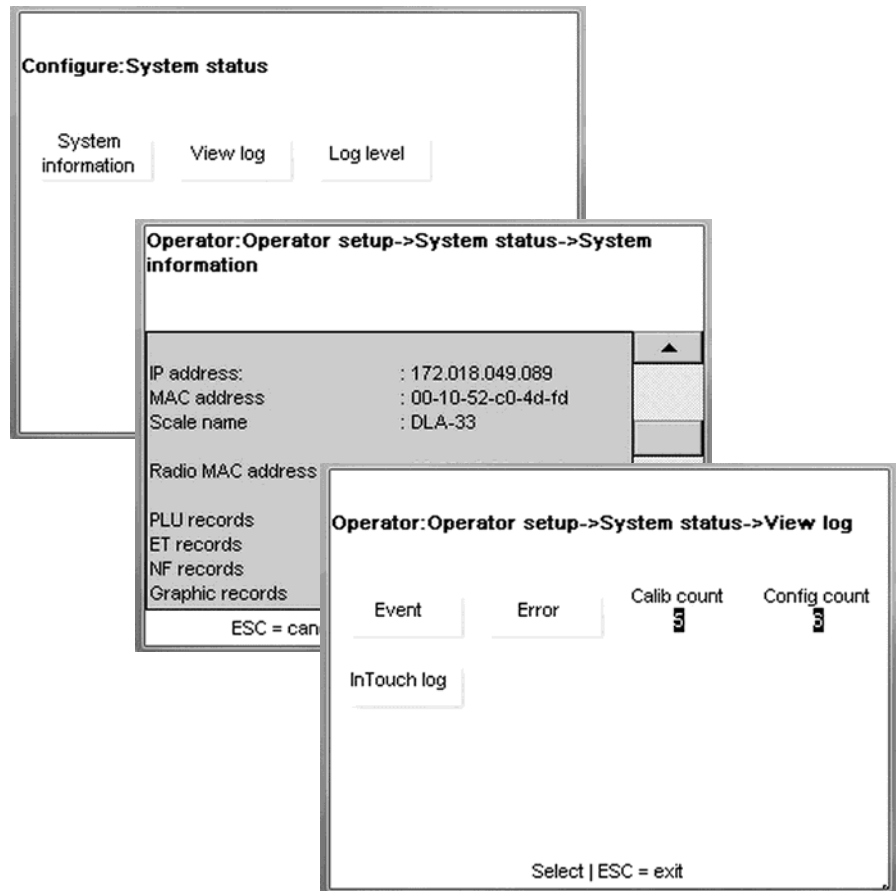

Set Home Screen

Select the default home screen to display on power up, when exiting configuration, and when completing a transaction.

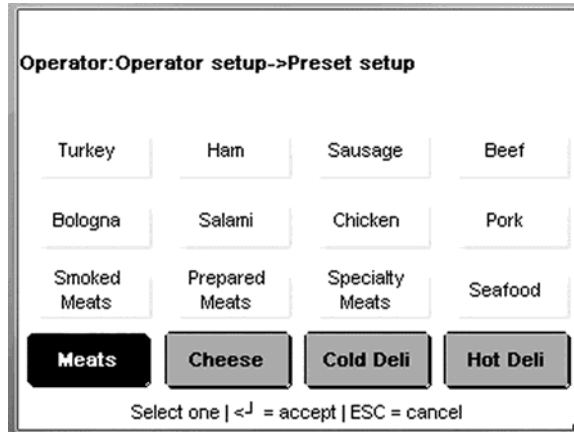

Restart

Restart the scale operating system.

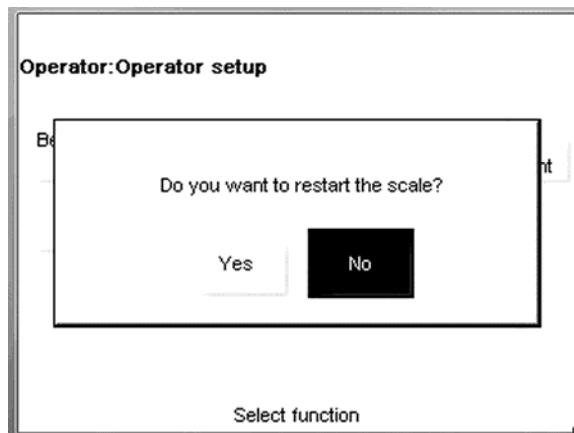

Display Settings

Configures functions for the customer and operator display such as button styles and contrast.

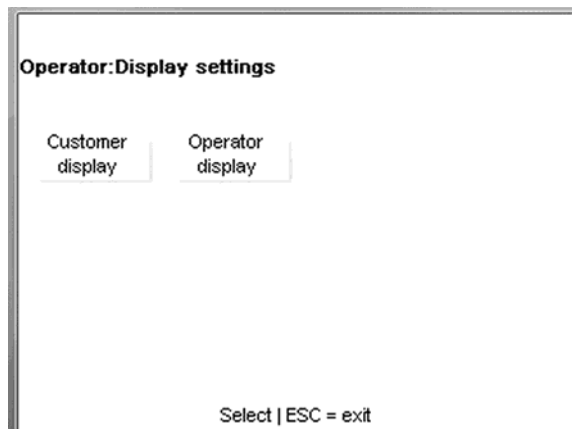

Customer Display Contrast

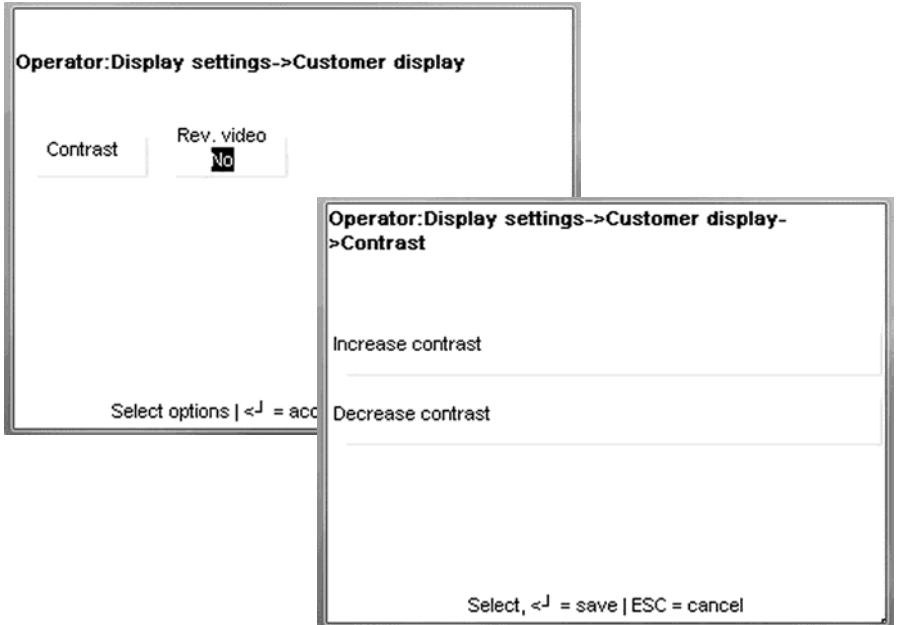

Operator Display Contrast and Button Styles

To set contrast, press the Contrast button and then the Info button three times. Next, press 1 to decrease or 2 to increase the contrast. The button style default is Style 1. Style 2 can be selected that has a defined button outline on four sides.

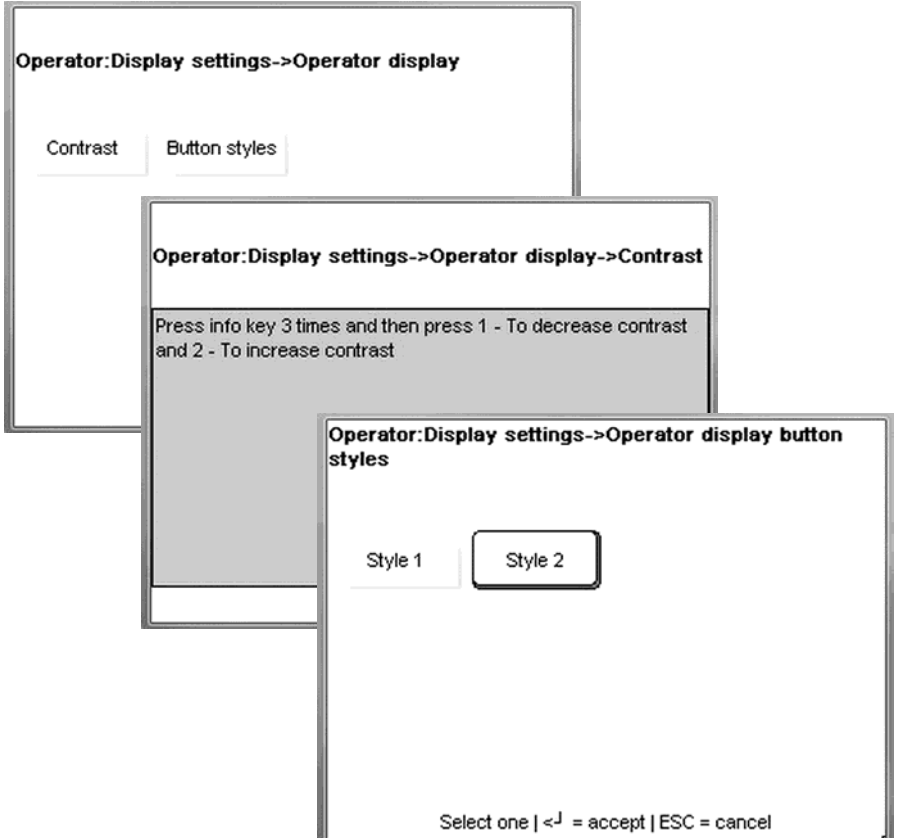

Calibration Audit Trail

Display calibration log.

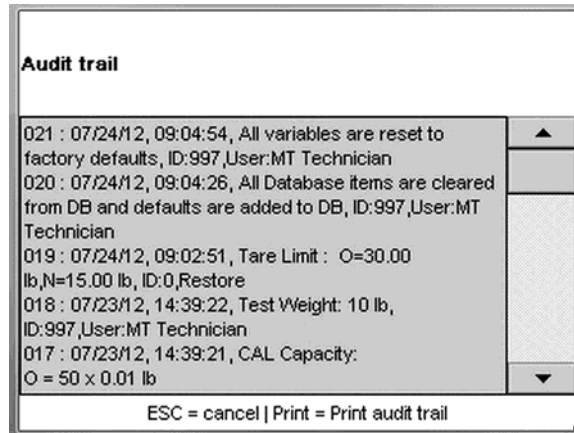

Label Printer

Set the label size, delivery method, eject length, and measure/print test label.

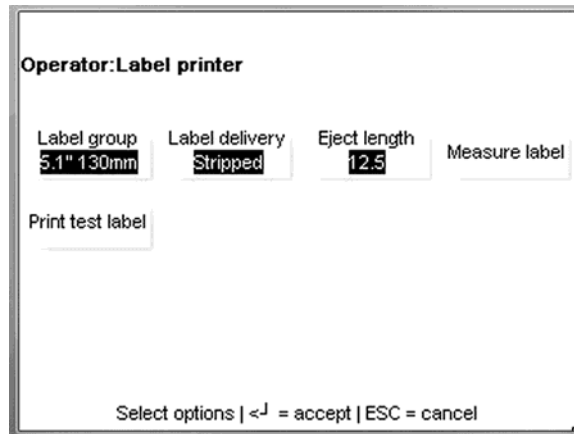

Label Group

Label Group selects the label length.

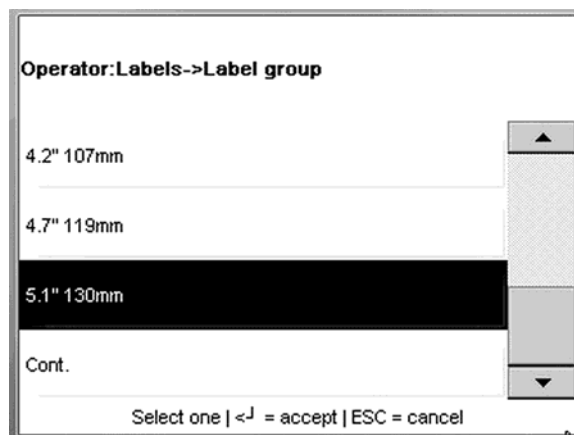

Delivery Method

Select Stripped or Unstripped. Stripped delivery peels the label from the liner and delivers on the label ready to apply to a package. The liner is wound around a takeup spool in the back of the printer. Unstripped delivers both the label and liner. Unstripped can be used when printing a large batch of labels that can be applied to the package at a later date. Refer to the labels chapter for installing the labels in Stripped or Unstripped applications.

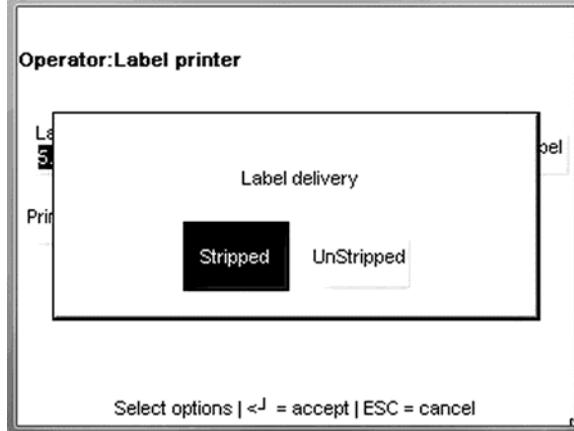

Eject Length

Eject length is the position (in millimeters) where the label stops after printing. If set to low, the label may be hard to peel from the liner. If set to high, the label may fall off the printer after it prints. The default value is (12.5).

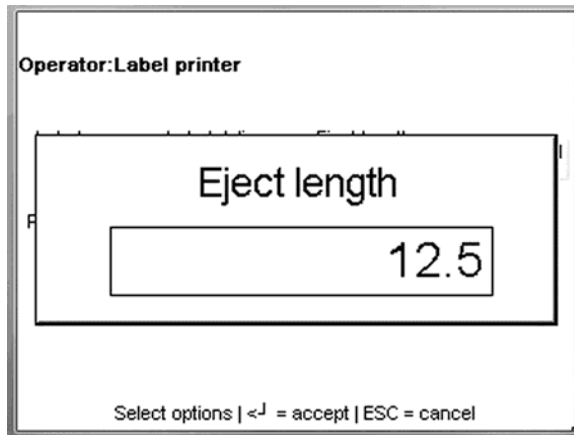

Print Test Label

Prints a test label used to verify positioning of the field on specified label formats.

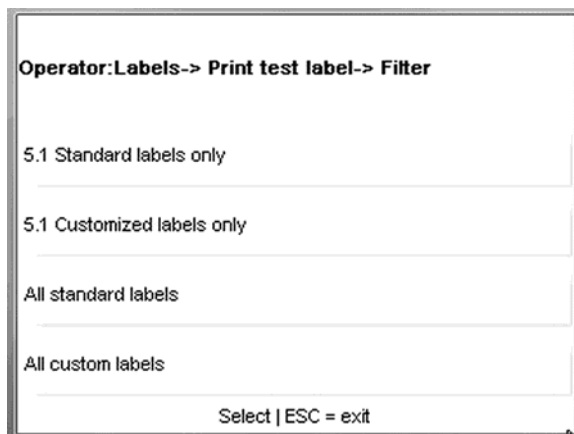

Preset

Add, edit, or delete preset buttons.

Operator:Preset

Select page	Edit page name	Swap pages	Delete page
Program preset	Edit preset name	Swap presets	Delete preset
Reaction Edit	Edit group name	Swap groups	Delete group

Select options | <J = accept | ESC = cancel

Select Page

Select the page to edit by touching the button and then press the Enter button to accept.



Operator:Preset->Select page

Turkey	Ham	Sausage	Beef
Bologna	Salami	Chicken	Pork
Smoked Meats	Prepared Meats	Specialty Meats	Seafood
Meats	Cheese	Cold Deli	Hot Deli

Select one | <J = accept | ESC = cancel

Edit Page Name

Touch the page name to edit and press the Enter button.



Operator:Preset-> Edit page name

Turkey	Ham	Sausage	Beef
Bologna	Salami	Chicken	Pork
Smoked Meats	Prepared Meats	Specialty Meats	Seafood
Meats	Cheese	Cold Deli	Hot Deli

Select one | <J = accept | ESC = cancel

METTLER TOLEDO Impact S® User's Guide
OPER Button

Next, edit the page name on the keyboard and press the Enter button to accept the changes.



Operator:Preset-> Edit page name

Turkey										▲
										▼
!	@	#	\$	%	?	&	*	FN		
q	w	e	r	t	y	u	i	o	p	
a	s	d	f	g	h	j	k	l	CR	
SFT	z	x	c	v	b	n	m	SPACE		

Swap Pages

Press the Swap Page button. Next press the first button to swap.

Operator:Preset-> Swap pages

Turkey	Ham	Sausage	Beef
Bologna	Salami	Chicken	Pork
Smoked Meats	Prepared Meats	Specialty Meats	Seafood
Meats	Cheese	Cold Deli	Hot Deli

Select destination | <J = accept | ESC = cancel

Then, press the button second button to swap positions with the first.

Operator:Preset-> Swap pages

Turkey	Ham	Sausage	Beef
Bologna	Smoked Meats	Chicken	Pork
Salami	Prepared Meats	Specialty Meats	Seafood
Meats	Cheese	Cold Deli	Hot Deli

Select one | ESC = cancel

Press the page to delete and the C button on the keypad to continue.



Operator:Preset-> Delete page

Turkey	Ham	Sausage	Beef
Bologna	Salami	Chicken	Pork
Smoked Meats	Prepared Meats	Specialty Meats	Seafood
Meats	Cheese	Cold Deli	Hot Deli

Select one, C = delete | <J = accept | ESC = cancel

Touch Ok to delete the page or Cancel to abort.

Operator:Preset-> Delete page

Do you want to delete?

Ok Cancel

Meats **Cheese** **Cold Deli** **Hot Deli**

Select one, C = delete | <J = accept | ESC = cancel

Program Preset

To program presets on a page, touch any blank button to add a new preset, or touch an existing preset to edit that preset.

Operator:Preset-> Program preset

GROUND CHUCK	Ham	Sausage	Beef
Bologna	Salami	Chicken	Pork
Smoked Meats	Prepared Meats	Specialty Meats	Fresh Fish
			▶

Select one | <J = accept | ESC = cancel

Enter the department where the PLU is stored.

Operator:Preset-> Program preset

Department

0

Select one | <J = accept | ESC = cancel

Enter the PLU number.

Operator:Preset-> Program preset

PLU:

291

Select one | <J = accept | ESC = cancel

Edit the Preset description. Press the Enter button to save and exit or the ESC button to exit without saving.

Preset key text

HOT BARBEQUED

!	@	#	\$	%	?	&	*	FN	
q	w	e	r	t	y	u	i	o	p
a	s	d	f	g	h	j	k	l	CR
SFT	z	x	c	v	b	n	m	SPACE	



Save and Exit



Exit without saving

Edit Preset Name

Select the page and then the preset. Edit the name and press the Enter button to save and exit.

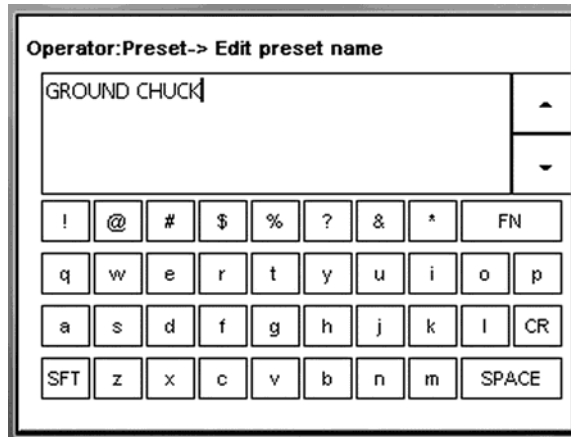

Swap Presets

Touch the preset to move and then touch the destination where the preset will move to.

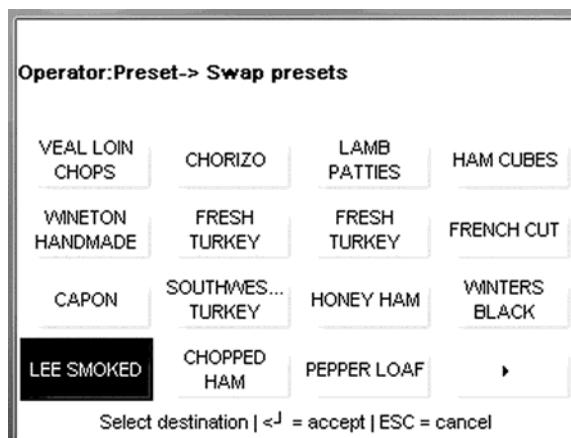
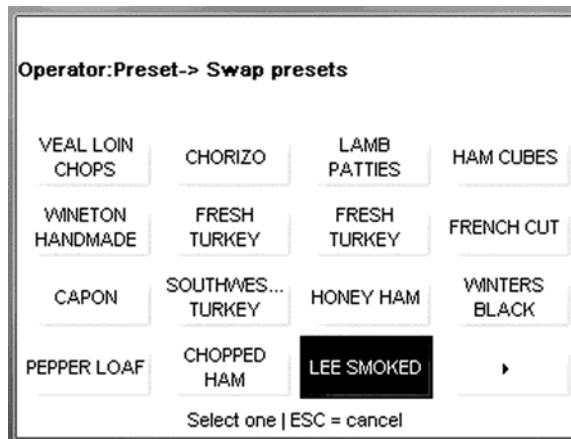

METTLER TOLEDO Impact S® User's Guide
OPER Button

Delete Preset

Touch the preset to delete and then press the C button on the keypad or ESC to cancel.

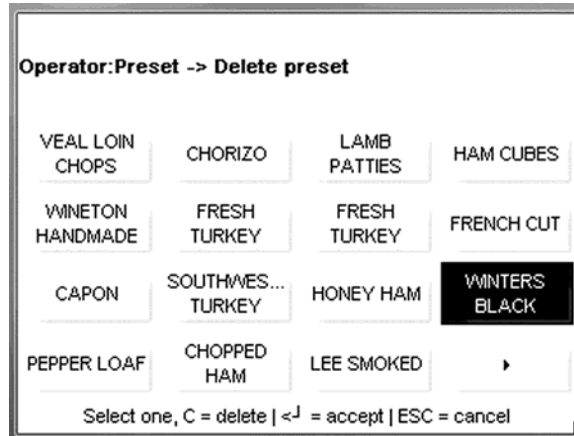

Press Ok to delete the preset or Cancel to abort.

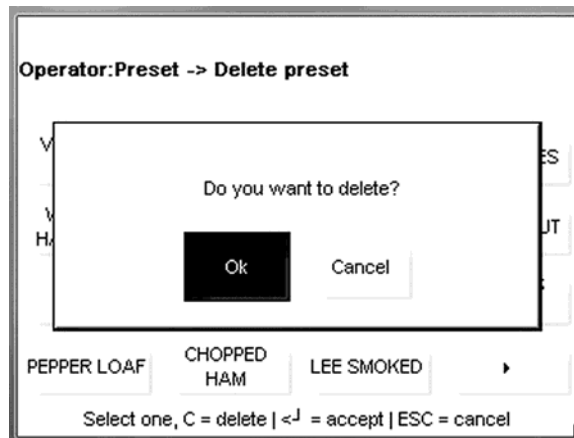

Reaction

Select how the preset buttons will react when pressed. Edit will call the PLU and open the PLU screen. The Print button must be pressed to print the label. Print will call the PLU and automatically print the label.

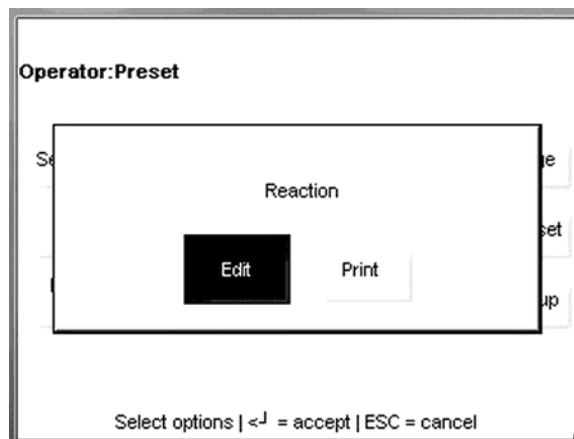

Edit Group Name

Touch the group button to edit. Edit the text and press the Enter button to save and exit or the ESC button to exit without saving.

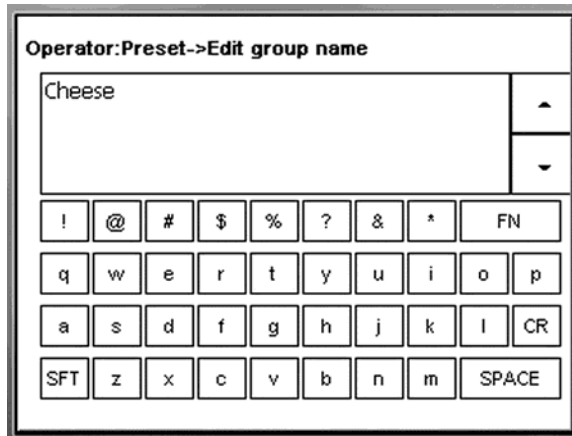
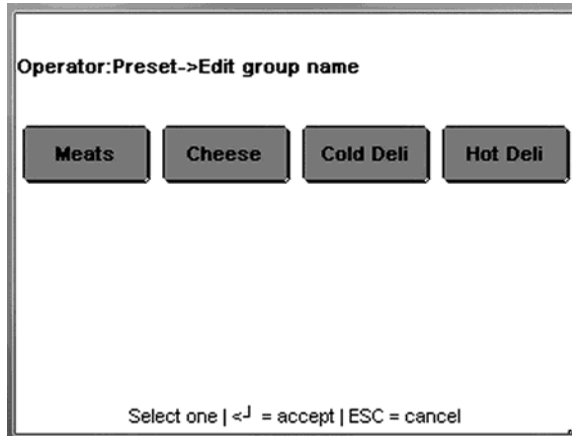

Swap Groups

Touch the button to move and then touch the destination where to move the button.

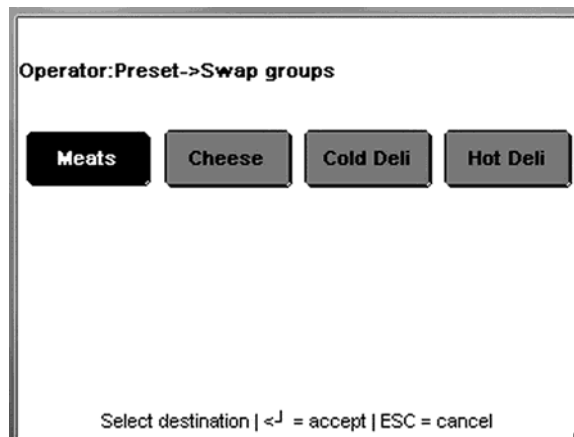

Delete Group

Touch the group to delete and then press the C button on the keypad to confirm. Press the ESC button to exit and cancel without saving.

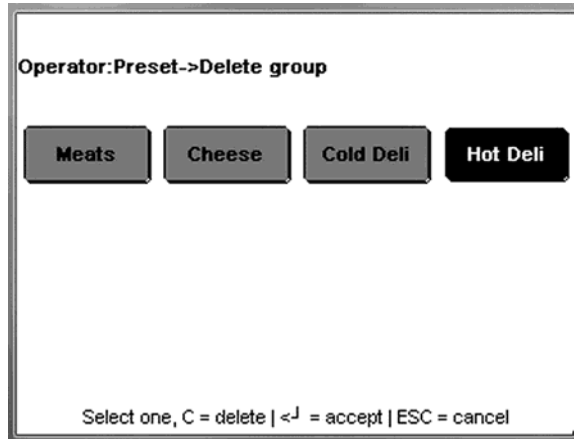



Note: Quick Edits is not available in Client Mode.

Quick Edits (Standalone Mode Only)

Quick Edits allows changes to some of the more common fields in the PLU record. Touch one of the buttons for the field to edit and type in the PLU number.

Operator:Quick edit

Price	Tare	Sell by date	Use-by day
Item number	Extra text	Nutrifacts	Group
Grade	Action code	Count	Special price type
Special price	Label style	Net weight	

Select,Edit | <J = accept | ESC = cancel

Operator:Quick edit

PLU:

1

Special price	Label style	Net weight
---------------	-------------	------------

Select,Edit | <J = accept | ESC = cancel

Enter the new value and then press the Enter button on the keypad to save the change and exit or press the ESC button to exit without saving.



Operator:Quick edit

Unit price

3.69

Special price	Label style	Net weight
---------------	-------------	------------

Select,Edit | <J = accept | ESC = cancel

Batch

Batch is used to print batches of labels (by-count or standard pack) that can be applied to the product in groups at a later date. To use the Batch function, call the first PLU.

Dept #:0		30 x 0.01 lb		Mem	
→0←		0.00 Gross lb		01:44:10 PM 07.31.12	
PLU: 401		DELI BY COUNT			
Unit price		\$4.04			
Total price		\$4.04			
Quantity	1	Pack date	07.31.12		
Total labels	1	Shelf life	08.14.12		

Press the OPER button. On the PLU screen, touch the Batch button.



Dept #:0		30 x 0.01 lb		Mem	
→0←		0.00 Gross lb		01:44:24 PM 07.31.12	
PLU: 401		DELI BY COUNT			
Extra text	Nutrifacts	Label fmt	More overrides		
Accum. Auto	Grade None	Blank field	Use-By 07.31.12		
Batch		Graphics	COOL		
Select And edit select, <J = accept ESC = cancel					

To print the items in the batch queue, press the Print button on the keypad. To change label quantity, touch the Change Label Qty button on the screen. To delete an item from the queue, touch the line and press the C button on the keypad.



Operator:View batch queue		
PLU	Qty	Description
00195195	001	Homestyle Southern
00001715	001	PASSION FRUIT & CH
Clear order	Change label qty.	
Select one C = delete ESC = Exit		

Operator Menu from Transaction Screen

When the OPER button is pressed while in a transaction screen, the following options will be displayed.



Dept #: 0 30 x 0.01 lb
Net
-0.02 lb 10:29:04 AM
07.25.12
PLU: 13 Virginia Baked Ham Low Sodium

Extra text []	Nutrifacts []	Label fmt	More overrides
Accum. Auto	Grade None	Blank field	Use-By 07.25.12
Batch	Graphics []		

Select And edit | select, <J = accept | ESC = cancel

Operator Menu from Transaction Screen

While on this screen, the Extra Text, Nutrifacts, Label Format, Accumulators, Grade, Use-By Date, and Graphics numbers can be overridden for the current transaction. The Blank Field function prevents selected fields on the label from printing. The "More Overrides" button will display any additional overrides available. The field can be changed if there is a button around it. Fields prohibited from overrides will not display a button around them. In the example above, the fields "Label Fmt" and "Batch" cannot be accessed.

Blank field override

Blank weight:	No
Blank unit price:	No
Blank total price:	No
Blank pack date:	No

Select options | <J = accept | ESC = cancel

Operator Menu from Transaction Screen

Memory Mode

Memory Mode will allow printing a receipt type label with multiple items on the label. To process a **Memory Mode** transaction, press the **MEM** key instead of the Print key. This will store the transaction data into Memory Mode and return the scale to the Home screen.

If a PLU is added to MEMORY that already exists in MEMORY, it is treated as a separate entry. This means that it is possible to have multiple transactions associated with the same PLU.

To complete the transaction, print the MEM key while at the home screen. **Subtotal**, **Remove Item** and **Clear MEM** keys are available on the memory mode menu.

Press the Subtotal key select the entry and press the **Print** key when ready.

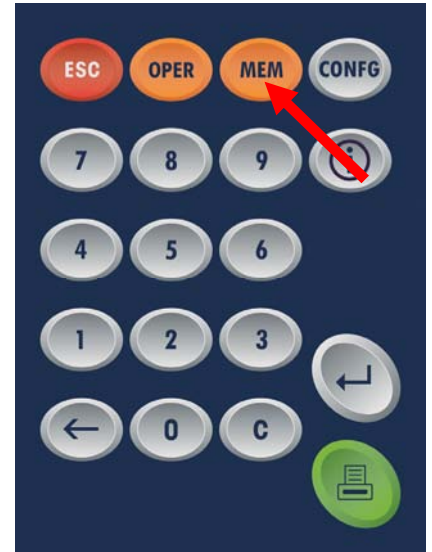

NOTE: When a PLU is added to MEMORY, the word **MEM** will display on the main screen alerting the operator to the presence of data in the MEMORY queue.

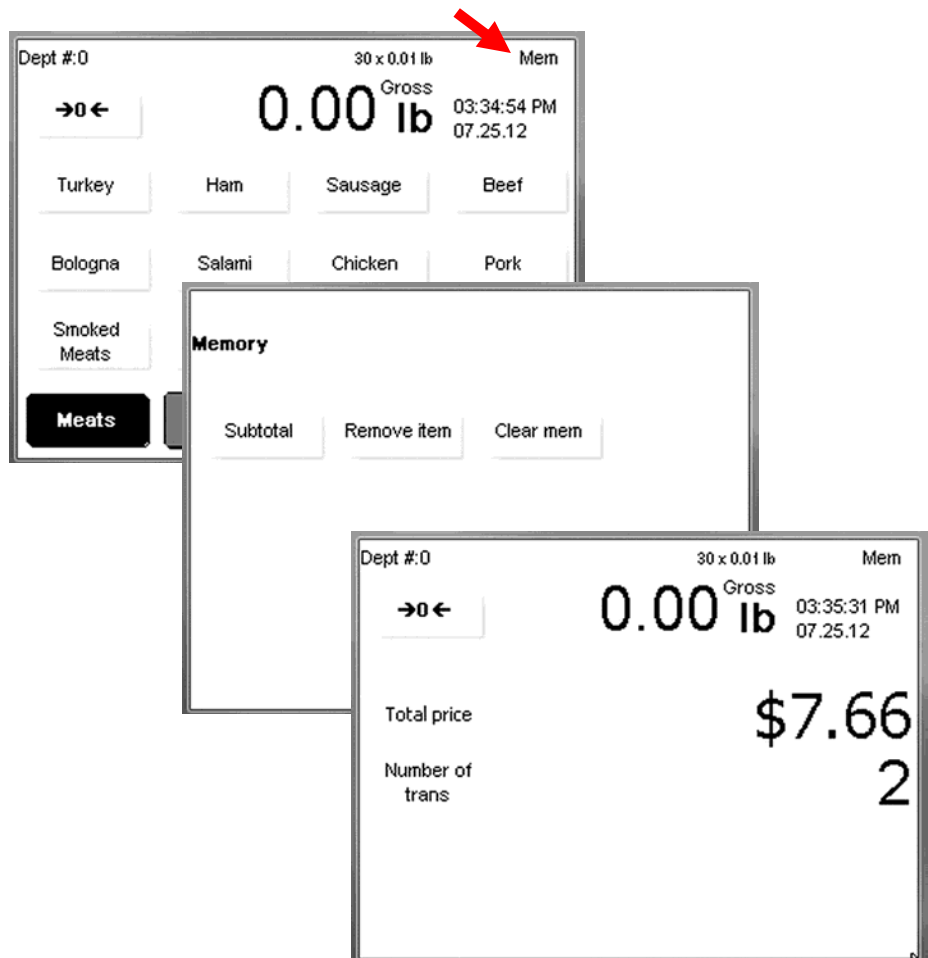

3

Setup Mode

Introduction

Setup for the Impact S[®] is accessed by pressing the gray **CONFIG** button on the Operator keypad.



From here the Item Database, Preset, Quick Edits, Labels, Unit Setup, Printer Setup, Security, System Status and Marquee settings can be accessed and modified.

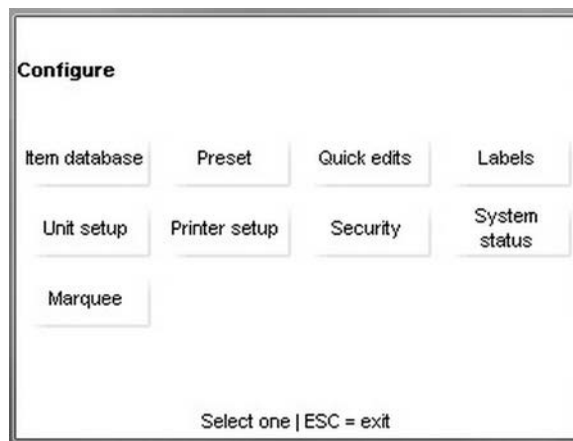

Database

There is extensive database support built into every Impact-S scale. The **Database** menu allows for the viewing and editing of various item parameters.

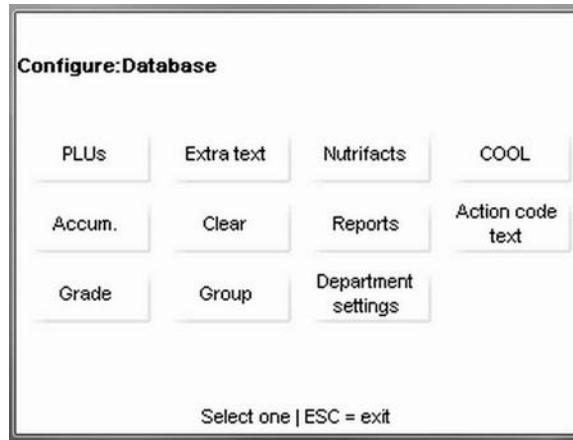

PLUs – Edit PLU record fields.

Extra Text – View and edit the Extra Text records.

Nutrifacts – Edit nutrifacts configuration.

COOL – Edit COOL configuration.

Accumulators – view and modify the accumulator lists.

Clear – used to delete entries from various databanks.

Reports – allows viewing of the various unit reports.

Action Code Text – Add or modify action code text.

Grade – Edit or add grade information.

Group – Add or edit groups to the database.

Department Settings – Configure department name, UPC, store address.

PLUs

The **PLUs** menu is used to edit fields of a PLU or to delete a PLU. The data is arranged in a scrollable list and can be modified simply by touching the appropriate field and following the menu prompts. PLUs from any department may be edited by choosing the desired department number at the **DEPT. NUMBER** prompt.

Configure:Database->Edit PLU fields

PLU: 291
Dept: 0

PLU: 291

Item number: 0000000000291

Desc1: HOT BARBEQUED

Desc2: CHICKEN

Select,Edit | <J = accept | ESC = cancel

Press the **Enter** button when done editing to save changes.

PLU Fields

The fields in the PLU record consist of the follow items.

PLU Field	Description
PLU Number	The PLU number can be from one to six digits (1-999999). Entering a new number allows entry of the field data. If the PLU currently exists, the current field data is displayed and can be modified.
Item Number	Used in the bar code data. The Item number can be from one to 10 digits depending on the barcode format.
Desc 1 Desc 2 Desc 3 Desc 4	Up to four lines of description can be programmed for the PLU record, up to 32 characters per line. To delete a character, press the Backspace button. To delete the complete line, first press the Shift button, then press Backspace.
PLU Type	The PLU Type determines the pricing mode that includes PRICE PER POUND, POUNDS FOR, PRICE PER HALF POUND, PRICE PER QUARTER POUND, BY COUNT, STANDARD PACK, and MANUAL. The choice of PLU type affects some of the menu options for the PLU Edit screen. If a change in PLU type is made, the default value for the new option is assigned.
Tare1/Ounces	This field changes depending on the PLU type. For Price Per Pound, Price Per Half Pound, Price Per Quarter Pound, and Pounds For PLUs, this field is titled TARE1 and when selected presents a numeric keyboard for the entry of the tare weight (default = 0.00). For Std Pack PLUs, it is titled OUNCES and when selected presents a numeric keyboard for the entry of the number of ounces in a pack. For By Count or Manual PLUs, this field is blank and disabled.

PLU Field	Description
Tare 2 Tare 3 Tare 4	This field changes depending on the PLU type. For Price Per Pound, Price Per Half Pound, Price Per Quarter Pound, and Pounds For PLUs, this field is titled TARE2 and when selected, a SELECT TARE2 TYPE screen is presented. Tare2 can be a fixed weight or forced so that the operator must enter the tare. A PERCENTAGE option is displayed but functions as the FIXED WEIGHT tare. If FIXED WEIGHT or PERCENTAGE are selected, a numeric keyboard prompts for the values of a tare weight (default=0.00). If FORCED is selected, the word FORCED appears in that field. This tare is available for the situation when 2 different tares are needed for the same product (ex. - with meat products, one tare is for the back room, and one tare is for the counter, after the meat has been re-packaged). For By Count, Standard Pack, and Manual PLUs, this field is blank and disabled. If Tare2 is not used, press the CANCEL button to bypass this entry.
Unit Price/Total Price	This field changes depending on the PLU type. For Price per Pound, Price Per Half Pound, Price Per Quarter Pound, and Pounds For PLUs, this field is titled UNIT PRICE and when selected presents a numeric keyboard for the entry of the unit price (default = \$0.00). For By Count and Standard Pack, it is titled TOTAL PRICE and when selected presents a numeric keyboard for the entry of the total price (default = \$0.00). For Manual PLUs this field is blank and disabled.
Shelf Life	Enter the number of days from 0 to 999 (default = 0). This is added to the current date when calculating the Shelf Life. Select Blank to blank the date from the label or Force to require manual entry of this value by the scale operator.
Use By Day	Enter the number of days from 0 to 999 (default = 0). Select Blank to blank the date from the label or Force to require manual entry of this value by the scale operator.
Group	Enter the group number between 1-500, or None.
Grade	Grade number from 1-16, or None.
Extra Text Number	Enter the Extra Text number to use with this PLU from 1-999999, or 0 for none.
Nutrifacts No	Nutrition Facts number to use with this PLU or none.
Graphics No	Enter the number (1-999999) corresponding to a graphics image resident in the database.
Action Code	Enter the Action Code (1-50). An Action Code will perform specific functions when the PLU is called depending on the function selected when downloaded from a host.
Barcode Type	UPC, EAN, GS1
Barcode Prefix	Select 1-9 for the prefix.

PLU Field	Description
Random Weight Type Format	<p>When a Type-2 UPC Bar Code is selected or if the Bar Code is configured as EAN, the format of the symbol must be configured, as follows: (N=Item Number, C=Price/Weight Check Digit, \$=Total Price, X=Bar Code Check Digit, #=Weight).</p> <p>UPC Formats</p> <p>0 = NNNNN C\$\$\$\$ X 1 = NNNNN O\$\$\$\$ X 2 = NNNNN N\$\$\$\$ X 3 = NNNNN S\$\$\$\$ X 4 = NNNNN C#### X 5 = NNNNN O#### X 6 = NNNNN N#### X 7 = NNNNN ##### X</p> <p>EAN Formats</p> <p>0 = NNNNN N\$\$\$\$ X 1 = NNNNN S\$\$\$\$ X 2 = NNNNS S\$\$\$\$ X 3 = NNNNN C\$\$\$\$ X 4 = NNNNC S\$\$\$\$ X 5 = NNNNN ##### X 6 = NNNNC ##### X</p>
Blank Fields	The Pack Date, Weight, Unit Price, or Total Price can be blanked (not printed) on the label. Touch the selection to toggle Blank or Normal.
Label Style	This field represents label styles 0-7 and will override the default label style for this PLU. Style 0 is the default format. Styles 1-7 will override the default style for a PLU.
DayGlo Number	Allows the user to select a Day-Glo graphic from a numbered list.
Security Label	Select either YES or NO to print as a security label
Special Price Type	<p>Select the type of discount, or press None for no Frequent Shopper Pricing.</p> <p>List Price - (similar to a Mfg. Suggested List Price). The amount entered is always higher than the PLU unit price.</p> <p>Member Price - Discounted price for By-Weight, By-Count, or Std. Pack PLUs.</p> <p>Percent Discount - A percentage off the Total Price for By-Weight, By- Count, or Std. Pack PLUs.</p> <p>Discount Per Pack - This is a specific amount off the Package Total Price for By-Weight, By-Count, or Std. Pack PLUs.</p> <p>Discount Per Unit - This is a specific amount off the Unit Price for By-Weight PLUs.</p> <p>None - This disables Special Pricing. The value will default to zero and editing is disabled.</p>
Special Price	Set a special price for the chosen PLU
Portions	Number of portions per package
Force COOL	Enforces COOL representation within the selected PLU.
Tracking	YES to apply internal reference tracking information for a specific COOL. Defaults to NO. Note: although internal, this tracking number can be placed on labels.
COOL Text	Custom COOL text linked records may be entered here
Production Text	COOL product text linked record number

PLU Field	Description
Country Text	COOL Country text linked record number
Pre Text	COOL Pre Text linked record number
TLV Text	Tag Length Value reference number
Large Graphics One Type	Linked record options: Extra Text, Graphics Record, Large Graphic Tracked
Large Graphics One Number	Selected LG One linked record number
Large Graphics Two Type	Linked record options: Extra Text, Graphic Record, Large Graphic Non-Tracked
Large Graphics Two Number	Selected LG Two linked record number
Pull Date	Date to pull the product.
Label Two Style	Alternate Label Style
Date Forwarding	Allows entry of a future packing date. No disables future date entries.

Extra Text



Optional USB keyboard is recommended.

Extra Text is used to modify the extra text records database. The number used to identify the record is linked to the PLU record by editing the PLU Extra Text Field and entering the corresponding number.

Select the number of characters per line (32, 42, 54) and then type in the text and press **Enter** to save the record and return to the previous screen. From there, edit another record or return to the **Database** screen.

Nutrifacts

Nutrifacts is used to add, modify or delete records. In addition to the nutritional information, the record contains the template for printing the label. Enter the number. If there is currently a NF record for this number, select Edit, Delete, or Cancel. If the record is new, select Add or Cancel.

Label – Select Single for the Nutrifact information to print on the main label in short-form or on a second label. Also select which of the two labels (if chosen) will be printed first.

Template – These choices select the correct template for the NF regulations and work with the NF Template setting in the Scale Settings. The setup in Scale Settings will override the NF field settings when Meat NF formats are selected. Select from Vertical, Tabular, Linear Portrait, Linear Landscape, Meat NF 2011 Simplified Vertical Small Pkg, Meat NF 2011 Simplified Vertical Large Pkg, Meat NF 2011 Simplified Vertical Narrow,

Meat NF 2011 Tabular Small Pkg, Meat NF 2011 Tabular Large Pkg, Meat NF 2011 Tabular Small Pkg Narrow, and Meat NF 2011 Tabular Large Pkg Narrow.



*Vertical



*Vertical



*Linear Landscape



*Linear Portrait

*Tabular



Simplified Vertical Wide (38 mm)



Simplified Vertical Narrow (29 mm)

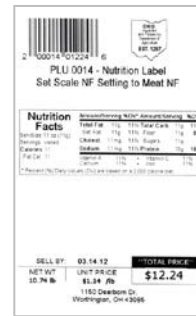

Tabular Small Pkg (64 mm)



Tabular Large Pkg (64 mm)



Tabular Small Pkg (56 mm)

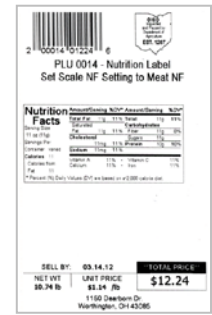

Tabular Large Pkg (56 mm)

Data – Select the **standard** or **simplified** template for the Nutrifact information.

Ser. Size Unit – Select the units for the serving size. Options include Ounces, Pieces, or custom Text.

Configure:Database->NutriFact edit
Rec: 1

Serving size
Select units

Ounces Pieces Text Cancel

Select options | <J = accept | ESC = cancel

Force Vit. – Force Vit. requires entry of vitamin data.

Servings – Enter the total servings per container.

Calories – Enter calorie information for the item.

Configure:Database->NutriFact edit->Calories
Rec: 1

Calories: 5

Calories from fat: 4

Calories from saturated fat Blank

Calories(%): 0

Select,Edit | <J = accept | ESC = cancel

Other Fields – Other fields include:

Configure:Database->NutriFact edit->Other fields
Rec: 1

Saturated fat(%): 9%

Poly unsaturated fat(g):

Mono unsaturated fat(g):

Cholesterol(mg):

Select,Edit | <J = accept

Configure:Database->NutriFact edit->Other fields
Rec: 1

Cholesterol(%): 13%

Sodium(mg): 14 mg

Sodium(%): 15%

Potassium(mg): Blank

Select,Edit | <J = accept | ESC = cancel

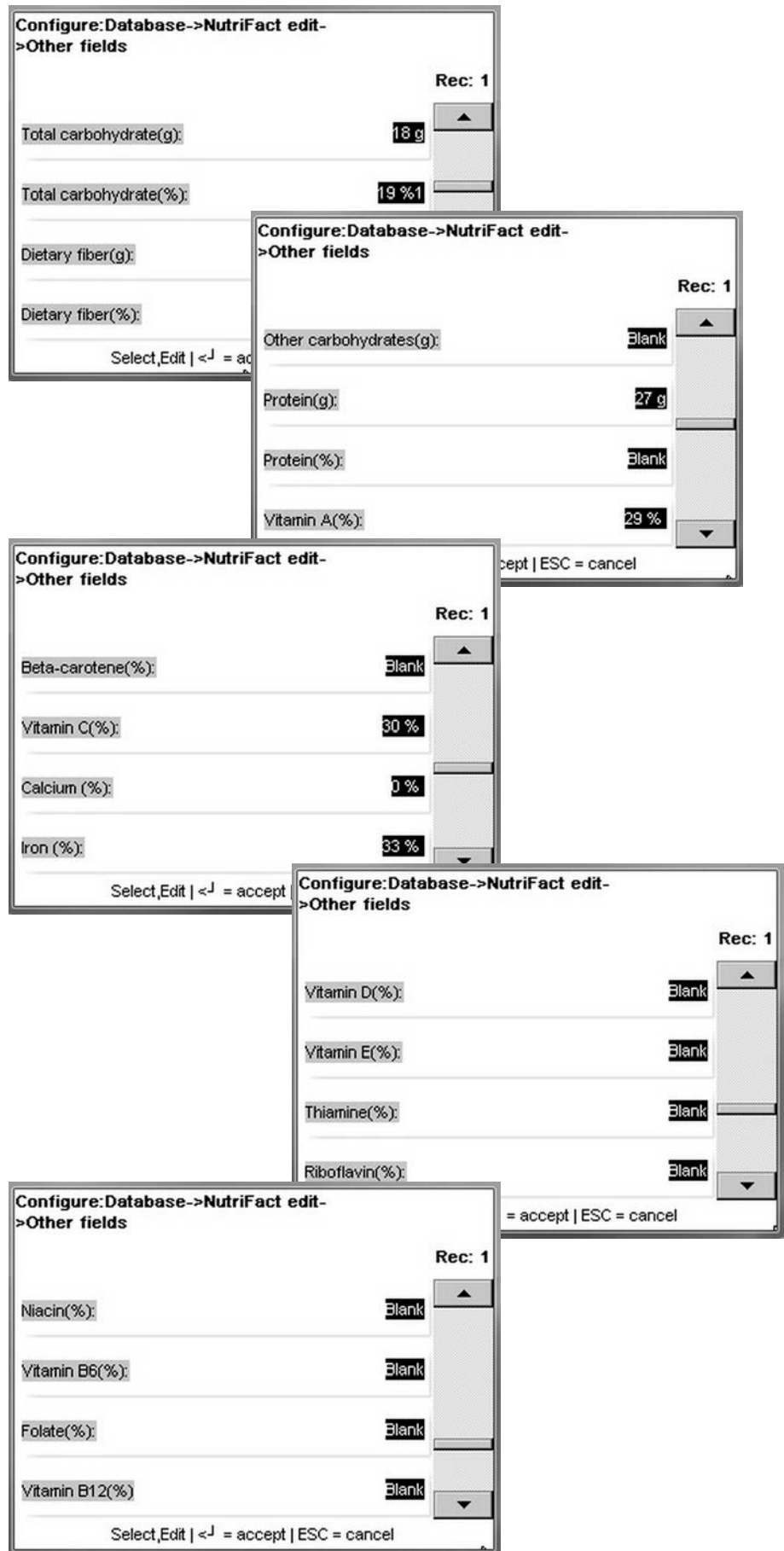

The image shows two overlapping screenshots of a database configuration window titled "Configure:Database->NutriFact edit->Other fields". The window displays a list of nutrient fields with their current values and a vertical scrollbar on the right. The top screenshot shows fields for Biotin(%), Pantothenic acid(%), Phosphorus(%), and Iodine(%), all with "Blank" values. The bottom screenshot shows fields for Magnesium(%), Zinc(%), Copper(%), and Trans fatty acid(g), with "Blank" values for the first three and "g" for the last. Both screenshots include a "Rec: 1" indicator and a "Select,Edit | <J = acc" prompt at the bottom.

Field Name	Value
Biotin(%)	Blank
Pantothenic acid(%)	Blank
Phosphorus(%)	Blank
Iodine(%)	
Magnesium(%)	Blank
Zinc(%)	Blank
Copper(%)	Blank
Trans fatty acid(g)	g

Press the **Enter** key when finished making any changes.

COOL

In Standalone Mode, the **COOL** section of the **Database** menu is used to edit or add new COOL (Country of Origin) records.

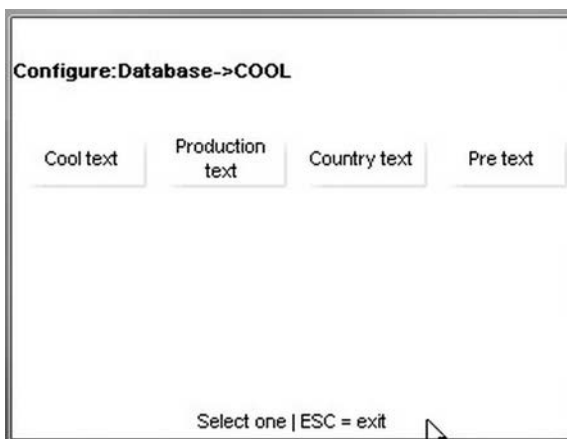

Optional USB keyboard is recommended.

Country of Origin Labeling (COOL) is information assigned to a PLU that designates where a product came from and where it was processed. COOL records must be assigned to a PLU in order to print. COOL implementation involves a combination of COOL Text Records, COOL Production Text Records, COOL Countries, and possibly COOL Pretext.

COOL is supported through specialized Extra Text Records and lists of extra text records that are associated with the PLU record. The operator can choose a preconfigured COOL statement or, create custom COOL statements, and if enabled, enter tracking numbers.

COOL Text

COOL Text records contain the complete statement of how the product was harvested and where it was harvested. Common examples of a COOL Text record are "Wild Caught" or "Product of USA".

Multiple COOL Texts can be chained together to give an operator more selections. This is useful for a retailer that purchases an identical product from multiple countries. These types of lists are best created and maintained in MT SmartX or through other host software.

Production Text

Production text is a phrase in the list such as "Produced in", "Processed in". Production text is created the same way as COOL Text.

Country Text

Country text is a list of countries and the individual country names (literals). Country text and text lists are created the same as COOL Text as described above.

Pre Text

Pre Text is a word or phrase that prints before the COOL Text on a label. Pre Text is programmed into the PLU record and cannot be overridden by the operator. Pre text and text lists are created the same as COOL Text as described above.

COOL Records and Lists

COOL is supported through specialized Extra Text Records and Lists of extra text records created at the scale or downloaded to the scale. The Lists are then associated to the PLU



record and the application allows choosing a COOL text from a menu or to create custom COOL statements.

Chained Records

'ESC+nnnnnT' sequences can be embedded in the ASCII_TEXT. These chained COOL Text records are then used to populate the list of available COOL Text records.

COOL Linked Record Examples

COOL Text

Note: 000001 is a Record List

Linked Record Type	Linked Record #	Data
05	000001	<ESC>+500005T<ESC>+500006T<ESC>+500007T<ESC>+500008T
05	500005	Raised in – Canada; Harvested – Canada; Processed in – USA;
05	500006	Product of – Mexico; Processed in - USA;
05	500007	Born in - Canada; Raised in - Canada, USA; Processed in – USA;
05	500008	Harvested in – Mexico; Processed in – USA;

Note: It is also possible to reference a list number within a list.
Example: list 000001 is embedded within linked record 000002 below as element 2.

05	000002	<ESC>+500005T<ESC>+000001T<ESC>+500006T
----	--------	---

Production Text

Note: 000004 is a Record List

Linked Record Type	Linked Record #	Data
06	000004	<ESC>+600013T<ESC>+600014T<ESC>+600015T<ESC>+600016T
06	500013	Raised in
06	500014	Product of
06	500015	Born in
06	500016	Harvested in

Country Text

Note: 0000025 is a Record List

Linked Record Type	Linked Record #	Data
07	000025	<ESC>+000032T<ESC>+000033T<ESC>+000034T<ESC>+000035T
07	500032	Argentina
07	500033	Canada
07	500034	Mexico
07	500035	USA

Pre Text

Linked Record Type	Linked Record #	Data
08	000034	Farm Raised
08	000053	Wild

Individual Records

Individual records will typically be individual complete COOL statements. Examples: "Born in – Mexico; Raised in – Mexico, USA, Canada; Processed in - USA".

Note: punctuation convention used:

"-" after Production step.

"," between Countries.

"," after Production/Country entries.

COOL List records are the list of relevant COOL text for a specific PLU. The exception to this rule is the COOL Pre-Text; since it is a single text record the actual text record number is associated to the PLU record.

The COOL text records and the COOL Lists of text records are separated by record number ranges. Text Records have a record number assigned to them in the range of 0-

500000. Lists of text records have a record number assigned to them in the range of 500001-999999.

The identifiers used for COOL linked record lists must be in the 0-500000 range. The 500001-999999 range is reserved for the COOL text literals used to populate each list element. The type 8 record is used for the Pre-Text Portion of the COOL statement and points to a text literal.

COOL statements are a composite of the Pre-Text and User Selected COOL records. They are limited to 150 Characters.

The COOL system works by using Extra Text type 5, 6, and 7 links in the PLU record as the ID of the selection list to be displayed on the scale. COOL Extra text records are as follows:

- ET Type 5 - Records are preconfigured COOL declarations and lists of preconfigured records.
- ET Type 6 - Records are keywords or production steps and lists of keywords used when building custom COOL declarations. For example: "Raised In", "Product of", or "Processed In".
- ET Type 7 - Records are countries and country lists also used when building custom COOL declarations. For example: "U.S.A.", "China", "Chile", or "Mexico".
- ET Type 8 - Records are the COOL Pre-text Records that are described below. However, there are no pre-text record lists. Only a single pre-text record can be associated to the PLU.

COOL Text

COOL Text Records (link record type 5) are Country of Origin Labeling statements that are created either by the operator or downloaded from host and linked to one or more PLU's. COOL Text records contain the complete statement of where and how the product was harvested.

Common examples of a COOL Text record are "Wild Caught" or "Product of USA".

Multiple COOL Texts can be chained together to give an operator more selections. This is useful for a retailer that purchases an identical product from multiple countries.

In order to provide a chained COOL Text record, a list of COOL Text Records must be created and assigned to PLU so that when the operator calls the PLU, a list of options is presented on the scale display. COOL Text Records are chained together using [ESC]+ to form a list.

COOL Production Text

COOL Production Step (Link Record Type 6) - This record type is used by the operator to select the Production Text and to build a custom COOL Text record, if there isn't a default record.

Examples of Production Step are: Wild Caught, Farm Raised, Product Of, Born In, Raised In, Processed In, Harvested In and Imported From.

Multiple COOL Production Texts can be chained together to give an operator more selections. Product Text Records number must be above 500,000 and Production Text List number must be less than 499,999.

COOL Country Text

COOL Country Text (Link Record Type 7) – This record type is used by the operator to select the countries and build a custom COOL Text record if there isn't a default one.

Examples of Country Text are: Argentina, Australia, Bahamas, Bangladesh, and Belize.

Multiple COOL Country Texts can be chained together to give an operator more selections. Product Text Literals number must be above 500,000 and Product Text List number must be less than 499,999.

COOL Pre Text

COOL Pre text (Link Record Type 8) – This record type will be used by the operator to select the Pretext and build a custom COOL Text record if there isn't a default COOL Text record.

This record type is rarely used because the same content that it was designed for can be used in COOL Production Step.

Examples of Pretext are: Wild Caught and Farm Raised.

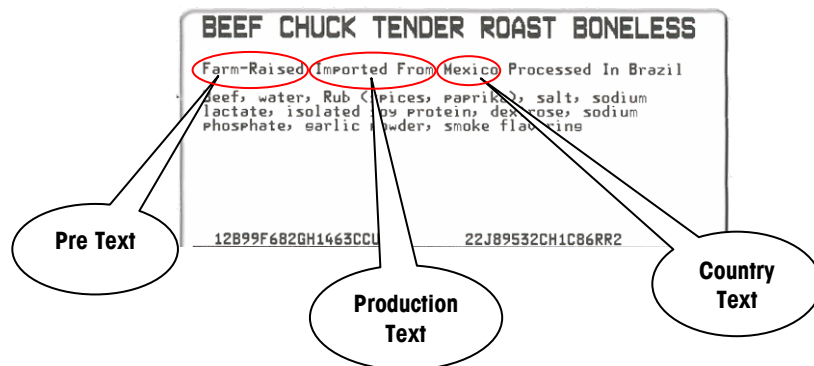



Optional USB keyboard is recommended.

Editing COOL Text

COOL Text can be edited on the scale (Standalone Mode only) or from a host program such as SmartX or WinDataback and downloaded to the Impact S. An external keyboard and a mouse are recommended when editing the text at the scale.

SmartX/WinDataback COOL Text

To create or modify COOL Text use the COOL editor in WinDataback or the COOL and COOL List Editor in SmartX.

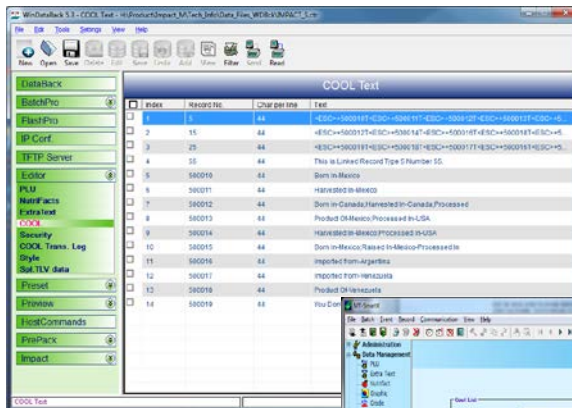

WinDataback 5.3

SmartX 5.x

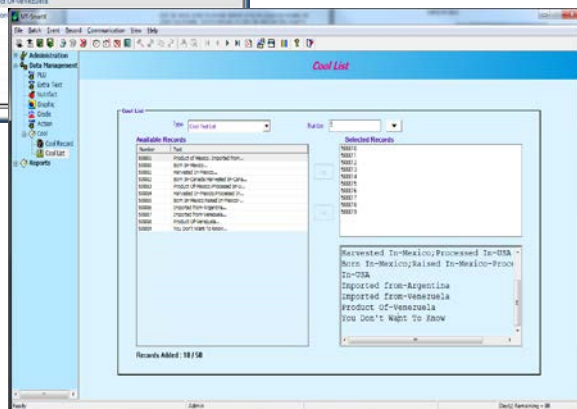

Standalone Mode COOL Text

From the Configure screen, press the Item "Item Database" button and then press the COOL button. Four categories of COOL can be edited.

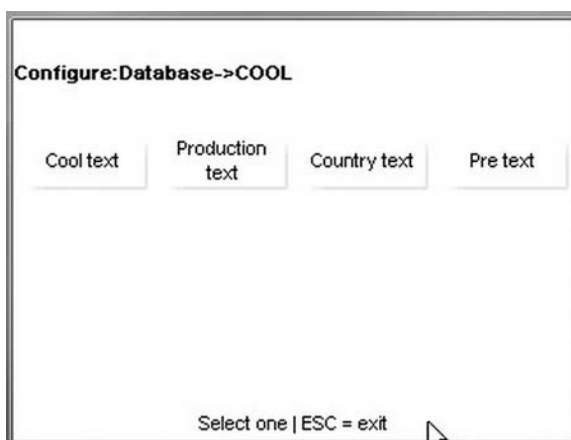

COOL Setup

To enable COOL features, open the Configure/Unit Setup/Scale Settings/COOL Options screen.

The image shows two screenshots of the 'Configure:Unit setup->Scale settings->Cool options' screen. The top screenshot displays the following settings:

- Cool: Enabled
- Cool text: Enabled
- Override: Enabled
- Restricted text: Enabled

The bottom screenshot displays the following settings:

- Restricted text: Enabled
- Tracking: Enabled
- Auto cool text print: Enabled
- First in list cool: Enabled

Both screenshots include a navigation bar at the bottom with the text: 'Select options | <J = accept | ESC = cancel'.

COOL

This enables or disables the COOL function.

COOL Text

Enable allows an override from the PLU screen. Disable displays data, but touch box is not active for overrides.

Override

Enable allows COOL to be canceled or overridden by the operator. Disable prevents overrides and the "No COOL" key will not be displayed.

Restricted Text

This setting governs the way the COOL screens are presented and how it operates.

Disabled - When set to Disabled and Force COOL = YES in the PLU record, the operator is required to manually select a COOL text and press the ENTER key to accept. Optionally, if OVERRIDE FORCED COOL is set to Enable, the default COOL text can be changed by selecting another COOL text or by selecting a Custom COOL text. The setting in the PLU record Force COOL must be set to YES for this feature to work. Maximum length of text is limited to 150 characters.

Enabled - When set to Enable, the last used COOL text is automatically highlighted and if no change is required, the ENTER key will accept the displayed COOL text.

Optionally, if OVERRIDE FORCED COOL is set to Enabled, the default COOL text can be changed by selecting another COOL text or by selecting a Custom COOL text.

Some other notes when using Restrict COOL Text Mode:

- Operator must always make a selection of COOL Text.
- If changing the default text, the operator will be presented with a message verifying the choice.
- Last selection on Custom COOL must be a country.
- Text wrapping shows up different on the screen.
- Maximum length of text is limited to 110 characters.
- Date format changes.

Tracking

The tracking feature can be used to enter an additional number or code to a specific product or vendor.

Auto COOL Text Print

When this is set to Enabled, the default COOL statement is printed without operator input. The operator has the option of overriding the default manually.

First in List COOL

When this is set to Enable, the default COOL statement is the MRU (Most Recently Used). When the MRU is blank, the first-in-list is the default. When set to Disable, the first-in-list is the default. This is used only when the Auto COOL Text Print is set to Enable.

Label Formats

In order for COOL to print on the label, the label format in use must have the COOL field configured in the format. Shown below are the field selection screen, the Field Edit screen for the COOL Text, and an example label with the COOL field configured.



Using COOL

In order for COOL to function, the following conditions must be met:

- COOL records must be created in the database.
- PLU records must be updated with the COOL numbers.
- COOL must be enabled in the scale setup.
- COOL Field must be configured on the label style.
- The COOL list must be created before the menu selection will work. SmartX or WinDataback will work for the list creation.

If the PLU has a COOL record already assigned, it will show when a PLU is called on the PLU screen as shown below. The MRU (Most Recent Used) will also display if a custom COOL was used for the last transaction.



If COOL is forced, the operator will be required to choose and verify the COOL record. To select a different COOL record, press **Cust COOL**. Select the Production Step and the Country to create a custom COOL. More choices can be displayed using the scroll bars.



For no COOL, press the No COOL button on the right. Press the Enter button to continue.

If tracking is enabled, a tracking number entry screen will next display.

PLU transaction:PLU operator->Tracking number

Tracking num1 45622224478522369

Tracking num2 45211145885696632

Select options | <J = accept | ESC = cancel

To accept the tracking numbers and continue, press the Enter button on the keypad. To change a number, touch the line to change and key in the new number using the keypad numbers. Press the Enter button on the keypad to save, and the Enter button again to continue.



Tracking num1

45622224478522369

!	@	#	\$	%	?	&	*	FN	
q	w	e	r	t	y	u	i	o	p
a	s	d	f	g	h	j	k	l	CR
SFT	z	x	c	v	b	n	m	SPACE	

From here, proceed as normal to complete the transaction.

Accumulators

The **Accumulator** menu is used to view and accumulator settings.

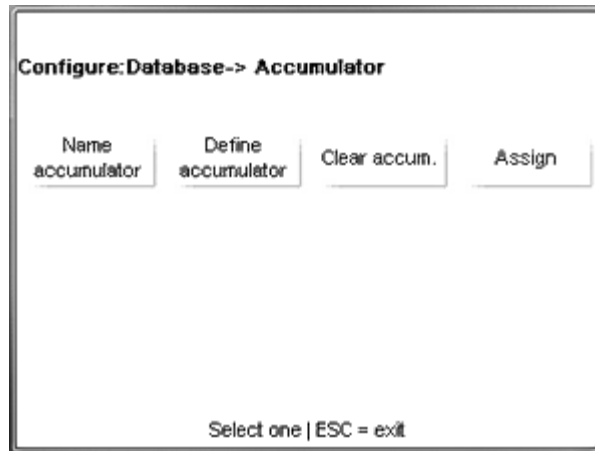

Name Accumulator – this function allows you to rename the existing accumulators or add new ones to the existing list. Select the accumulator you would like to rename by touching the line. Rename the accumulator and then press the **Enter** button on the keypad to save and exit.

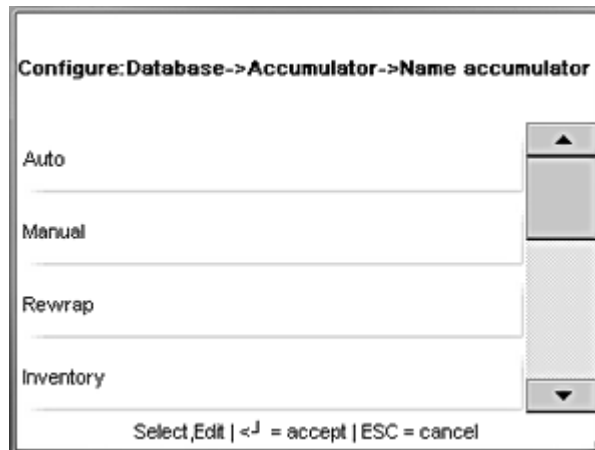

Define Accumulator – Enable or disable the existing accumulators. Yes enables and No disables the accumulator.

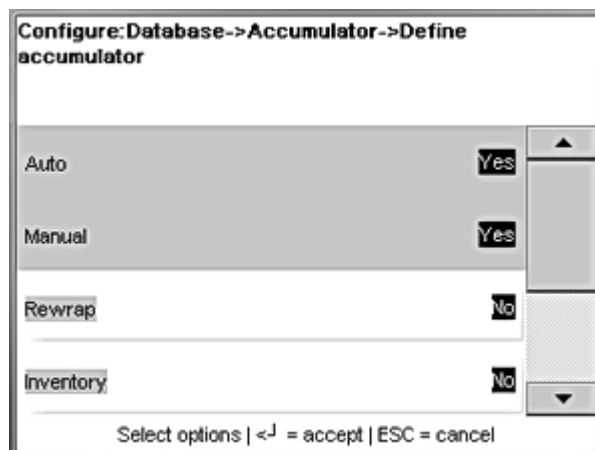

Clear Accumulator – used for deleting specific PLUs and other bits of data. Follow the menu prompts to make changes.

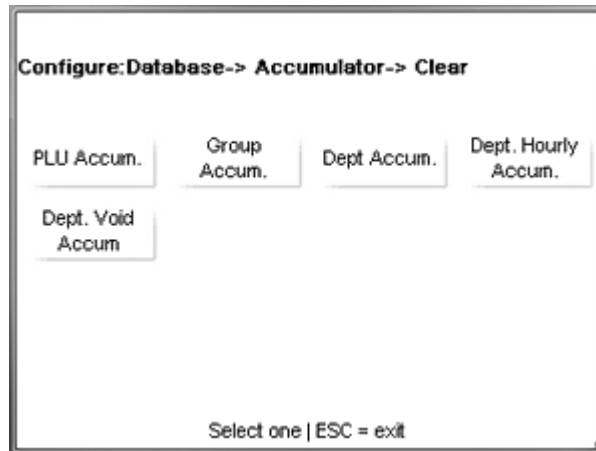

Assign – used to re-assign the accumulator types for Rewrap, Inventory, Shrink, or Combination. Each type can have a separate accumulator or they can all use the same one if needed.

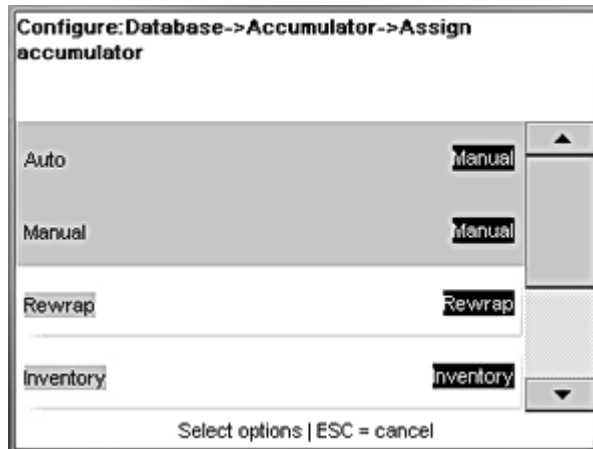

Clear

Clear deletes data. Touch the category to clear and follow the menu prompts to delete data. When complete, press **ESC** to return to the **Database** main screen.

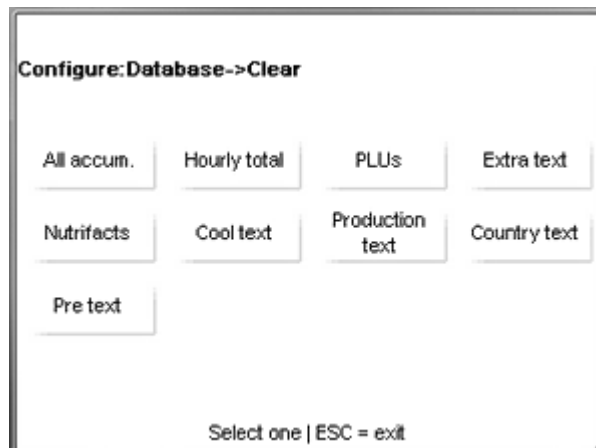

Reports

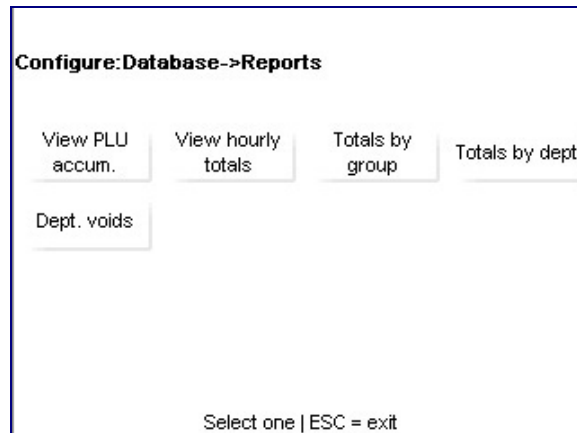

Pressing the **Reports button** at the **Database** screen opens the reports menu. Depending on the report they would like to view, press the corresponding button and follow the menus (Department, hours, date, etc.) until the desired report is reached.

Totals by Group – View the weight and value (among other categories) totals for all PLUs in a particular group. Enter in the group number and wait for the unit to scan.

Totals by Department – Same as **Totals by Group** but with all the PLUs in a particular department. Key in the department number and wait for the unit to scan.

Department Voids – enables a report to be viewed containing the weight totals, value totals and modified value totals (among others) of anything that has been voided out on the unit.

Action Code Text

The **Action Code Text** has three different functions:

- Display a special message to the operator via the operator screen.
- Over-ride the store address line on the printed label.
- Display a marquee message on the customer display.

Enter a two digit action code number.

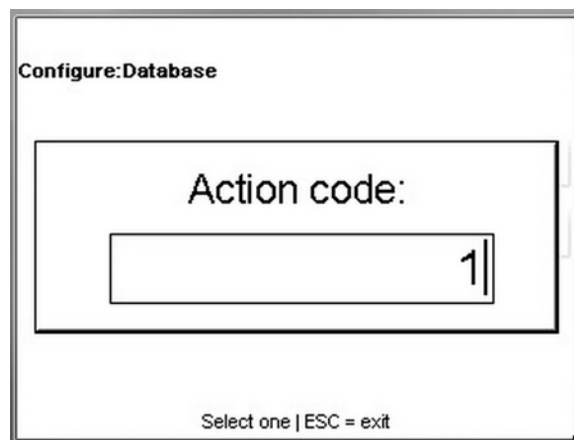

If the record does not exist, touch "Add" to add a new Action Code.

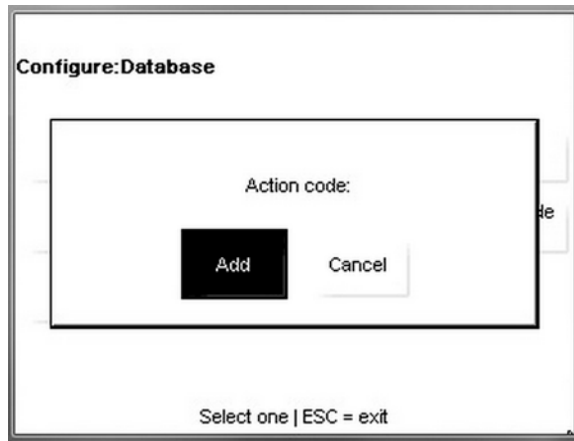

Touch the field to edit.

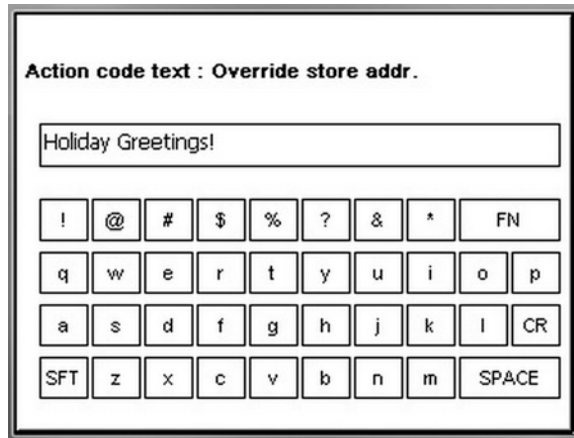
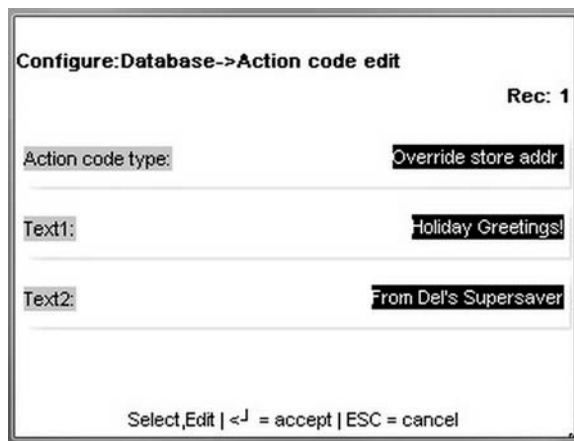

Press **Enter** when finished making changes.

Department Settings

Select the department. If the department current exists, select **Edit** or **Clear** or **Add** for a new department.

Configure:Database

Department no.

0

Select one | ESC = exit

Configure:Database

Department

Edit Clear Cancel

Select one | ESC = exit

Configure:Database->Edit department

Rec: 0

Dept. name: Del

UPC number: 00000001258845

Password: 0

Address1: Del's Supersaver #33

Select,Edit | <J = accept | ESC = cancel

Touch the fields to edit and make changes. When complete, press the **Enter** button on the keypad to save the changes.

Grade

The **Grade** function allows for editing grade descriptions. A keyboard screen opens to enter a string of text for the grade. The **Grade** field is limited to 23 characters. Press **Enter** when finished.

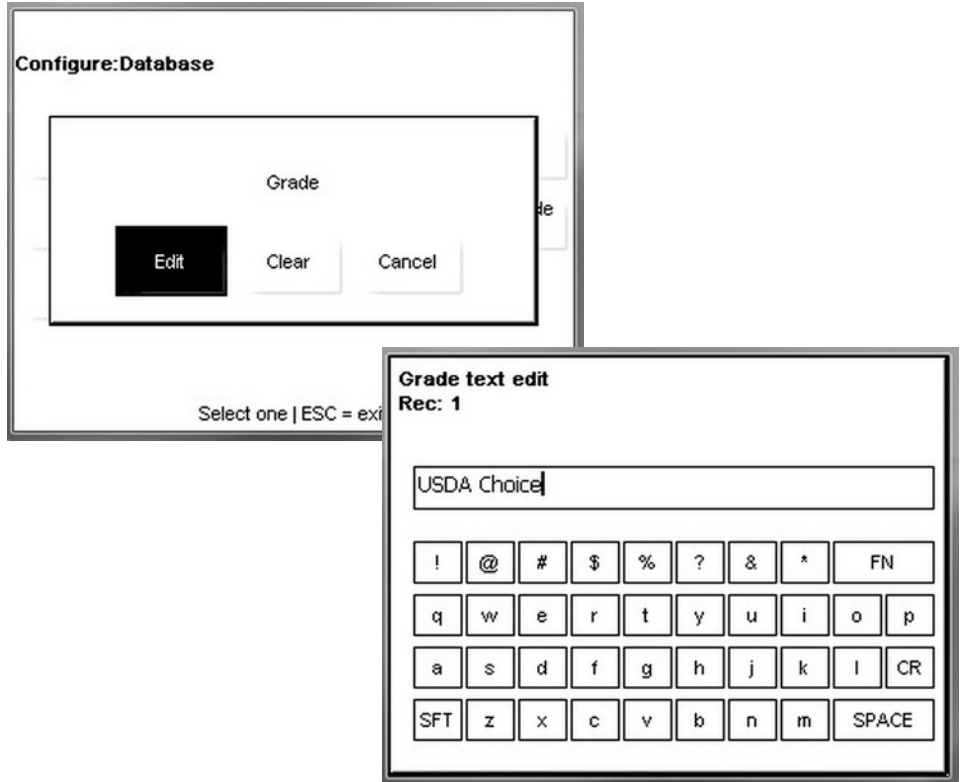

Group

Define and name any groups that can be used for reports.

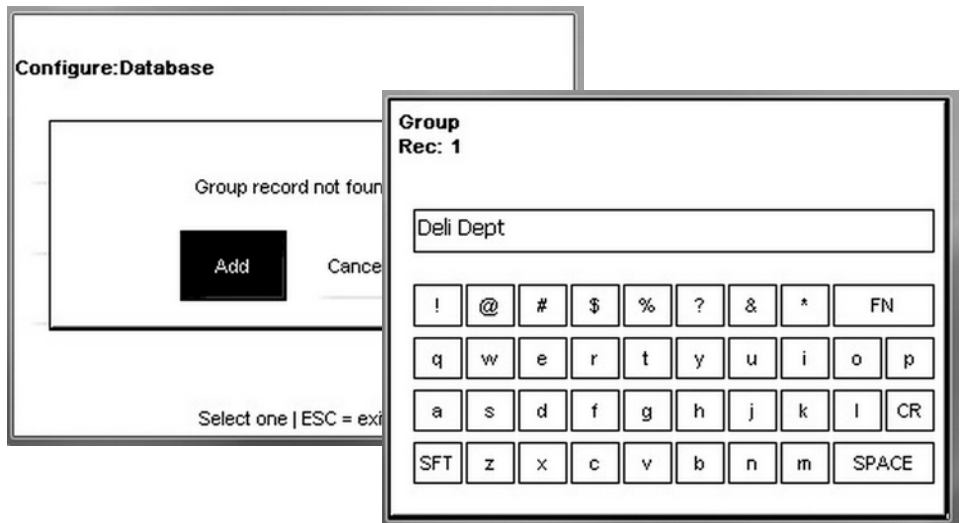

Press **Enter** when satisfied.

Preset

The Preset menu is used to create or modify preset pages and buttons used for quick PLU retrieval. For details, refer to Chapter 2 OPER Button, Presets.

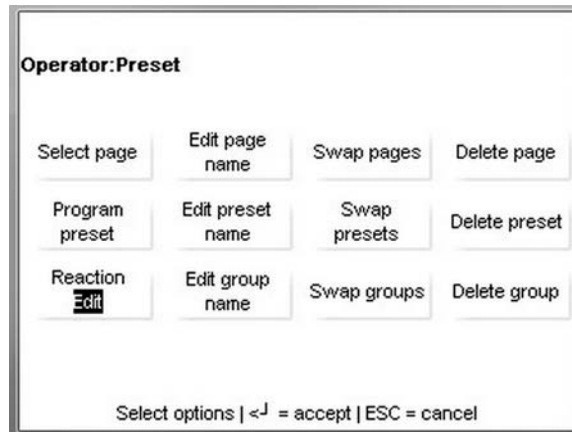

Included in this menu are the following functions.

Select Page – Select from the preset page to edit.

Edit Page Name – Modify the preset page's name.

Swap Pages – Move the page listing position.

Delete Pages – Permanently remove a preset page.

Program Preset – Create a new preset button.

Edit Preset Name – Modify a preset button's name.

Swap Presets – Move a button's position.

Delete Preset – Permanently remove a preset.

Reaction – Select **EDIT** and **PRINT** actions when the button is touched.

Edit Group Name – Modify a group's name.

Swap Groups – Move position of the group..

Delete Group – Permanently delete the group.

Quick Edits



Quick Edits is available only in Standalone mode. Not available in Client mode.

Quick Edits is used to make quick changes to commonly modified fields in the PLU record. To make changes to fields not listed in the Quick Edits menu, open the Database menu and select PLUs.

Configure:Quick edit

Price	Tare	Sell by date	Use-by day
Item number	Extra text	Nutrifacts	Group
Grade	Action code	Count	Special price type
Special price	Label style	Net weight	

Select,Edit | <J = accept | ESC = cancel

Touch the field button to edit, make any needed changes and press the Enter button on the keypad to save or ESC to cancel and exit the field.

Configure:Quick edit

Unit price

Special price Label style Net weight

Select,Edit | <J = accept | ESC = cancel

Configure:Quick edit

Tare1

Special price Label style Net weight

Select,Edit | <J = accept | ESC = cancel

Configure:Quick edit

Shelf life:

Special price Label style Net weight

Select,Edit | <J = accept | ESC = cancel

Configure:Quick edit

Use-by day:

Special price Label style Net weight

Select,Edit | <J = accept | ESC = cancel

Configure:Quick edit

Item number

Special price Label style Net weight

Select,Edit | <J = accept | ESC = cancel

Configure:Quick edit

Extra text

Special price Label style Net weight

Select,Edit | <J = accept | ESC = cancel

Configure:Quick edit

Nutrifacts

501

Special price Label style Net weight

Select,Edit | <J = accept | ESC = cancel

Configure:Quick edit

Group number:

0

Special price Label style Net weight

Select,Edit | <J = accept | ESC = cancel

Configure:Quick edit

Grade

1

Special price Label style Net weight

Select,Edit | <J = accept | ESC = cancel

Configure:Quick edit

Action code:

1

Special price Label style Net weight

Select,Edit | <J = accept | ESC = cancel

Configure:Quick edit

Count:

1

Special price Label style Net weight

Select,Edit | <J = accept | ESC = cancel

Configure:Quick edit

Special price type:

None % Discount/ pack % Discount/ unit

Feature price Member price % Discount UP

Special price Label style Net weight

Select,Edit | <J = accept | ESC = cancel

Configure:Quick edit

Member price

3.69

Special price Label style Net weight

Select,Edit | <J = accept | ESC = cancel

Configure:Quick edit

Label style:

0

Special price Label style Net weight

Select,Edit | <J = accept | ESC = cancel

Configure:Quick edit

Ounces:

0.0

Special price Label style Net weight

Select,Edit | <J = accept | ESC = cancel

Labels

The **Labels** menu configures the labels and formats used in the printer.

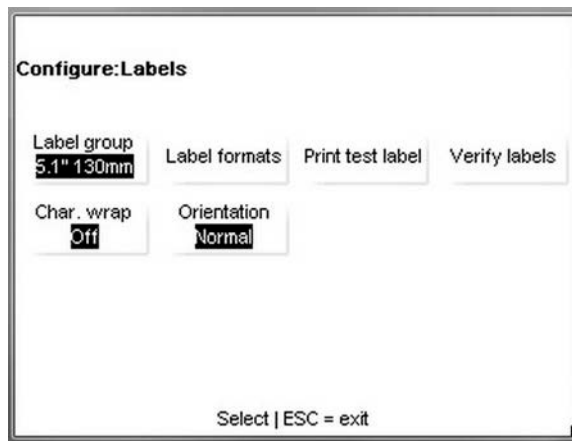

Label Group – Selects the size (length) of the labels in the printer.

Assign Styles – Select the format style of the labels for By-Weight, Prepack, By-Count, and Standard Pack.

Print Test Label – Prints a label of the selected size and style.

Verify Labels – Prints labels by a department and range of PLU numbers.

Char. Wrap – Turns on/off character wrap.

Orientation – Prints the label normal or inverts the label printing 180 degrees.

Label Group

Selects the size (length) of the labels in the printer and allows custom names for the labels. Touch the size to select and press the Enter button on the keypad to accept.

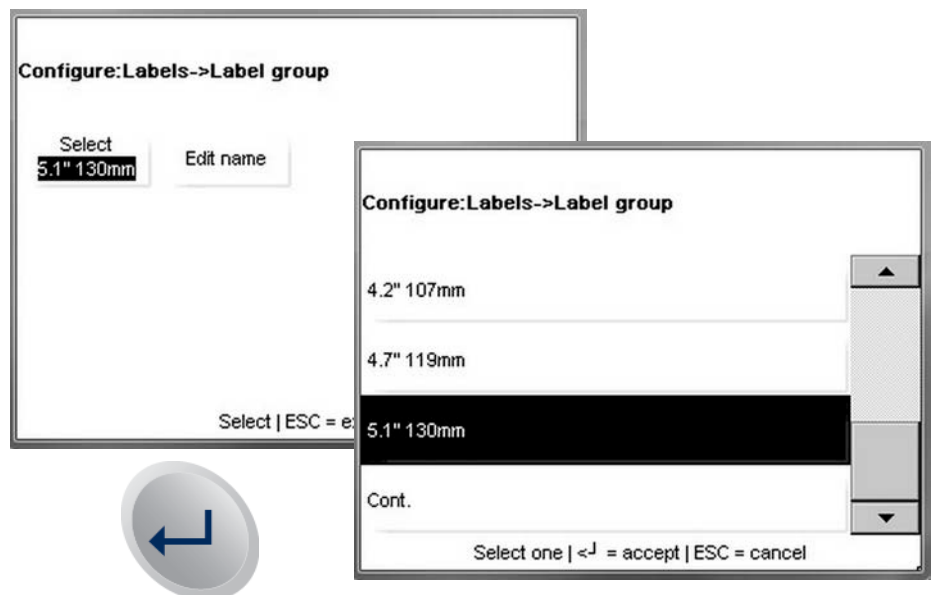

Edit Name is used to rename the label sizes if required. Type in the name and press the Enter button on the keypad to accept the change.



Configure:Labels->Label group->Edit label name

5.1" 130mm

!	@	#	\$	%	?	&	*	FN	
q	w	e	r	t	y	u	i	o	p
a	s	d	f	g	h	j	k	l	CR
SFT	z	x	c	v	b	n	m	SPACE	

Label Formats

Configure:Labels

ByWeight

PrePack

ByCount

StdPack

Select | ESC = exit

ByWeight – select to assign label styles for By-Weight transactions

PrePack – select to assign label styles for PrePack transactions

ByCount – select to assign label styles for By-Count transactions

StdPack – select to assign label styles for Standard Pack transactions

Receipt – select to assign label styles and specific formatting to the printing of receipts

Verify – select label format to apply to **Verify Label** printings

Totals – select label format to apply to **Totals Labels**

NF Label Format – select label format to apply to **Nutrifact Labels** (done at NF programming)

Print Test Label

This menu is used to print test labels.

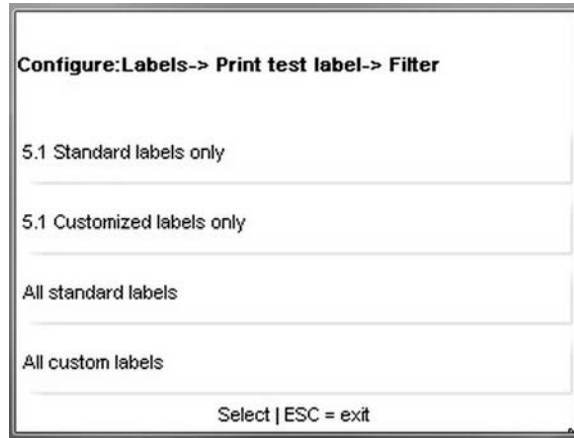

Verify Labels

This function will print PLUs by department. A range of PLU numbers can also be printed. Touch the **Begin Printing** button to start printing. Once this process begins, it can be stopped by pressing the **ESC** button on the keypad.

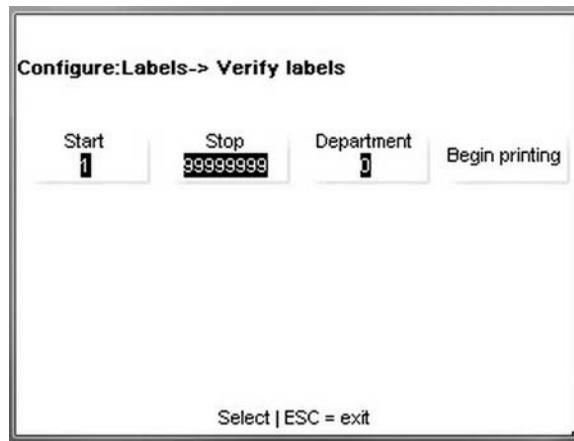

Char. Wrap

When ON, text will wrap at the predefined boundary of the field. For example, if an Extra Text record has been configured for 42 characters per line, if the text is longer, it will wrap to the next line. When OFF, the text will wrap at the boundary width of the label.

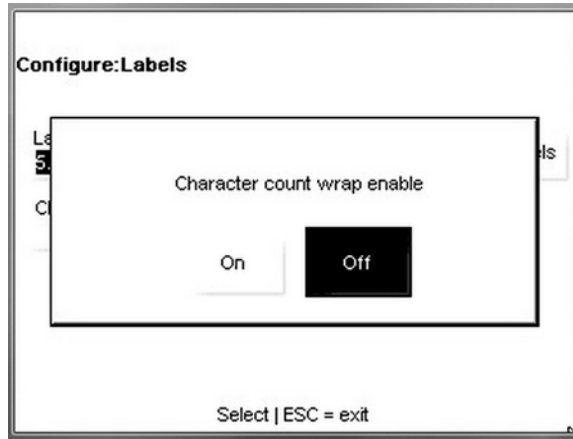

Orientation

This setting inverts the printed label 180 degrees.

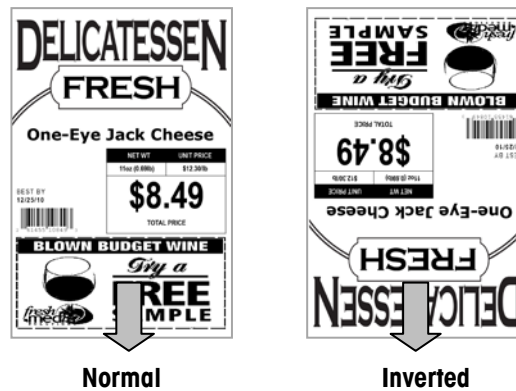

Unit Setup

Pressing the **Unit Setup** button opens the setup menu.

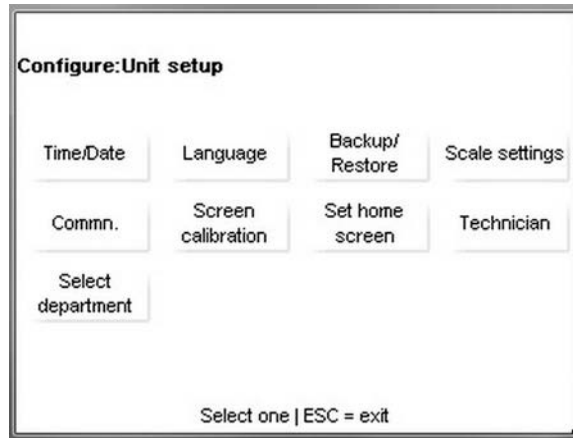

Time and Date – Change or format the unit's time and date settings.

Language – Select the default language.

Backup/Restore – Backup or restore scale database.

Scale Settings – Scale setup.

Commn – Communication settings (Ethernet network).

Screen Calibration – Calibrate the touchscreen.

Set Home Screen – Select the default preset screen.

Technician – Accesses the password-protected Technician menu.

Select Department – select the default department for the PLU database.

Time and Date

The **Time and Date** menu allows you to format or set the scale's date and time. Press the **Enter** key after making any changes to apply your preferences.

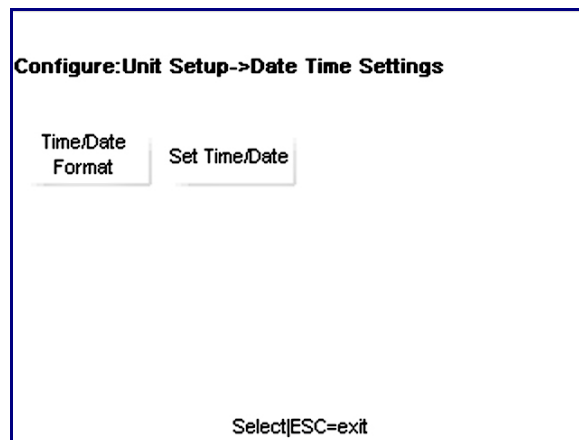

Time/Date Format – select to format the unit’s time and date settings. Select parameters including adjustment for time zones and seasonal daylight savings, as well as apply the particular date and time orders (i.e. month/day/year or 11:00pm versus 23:00).

Configure:Unit Setup->Date Time Settings->Time & Date Format

Time Format: 12:MM:SS

Date Format: MMM/DD/YY

Date Field Separator: |

Daylight Savings Time: Enabled

Select options|Enter=accept|ESC=cancel

Set Time/Date – select to set the time and date to match your region.

Configure:Unit Setup->Date Time Settings->Set Time & Date

Hour: 12

Minutes: 27

AM/PM: PM

Month: 10

Select,Edit|Enter=accept|ESC=cancel

Language

Select English, French, or Spanish.

Configure:Unit setup->Language

Operator display language: English

Scale language: English

External keyboard: English

Select options | <J = accept | ESC = cancel

Press the **Enter** key when finished to save your choices.

Backup/Restore



Note: A licensed USB Drive is required to use the Backup/Restore functions on the Impact S.

Backup/Restore will save or read configuration and database data to internal flash or an external USB drive. The **Export Log** feature enables you to move log files to \service\log directory for export. **Copy** is used to copy files such as images from the compact flash card on an external USB drive.

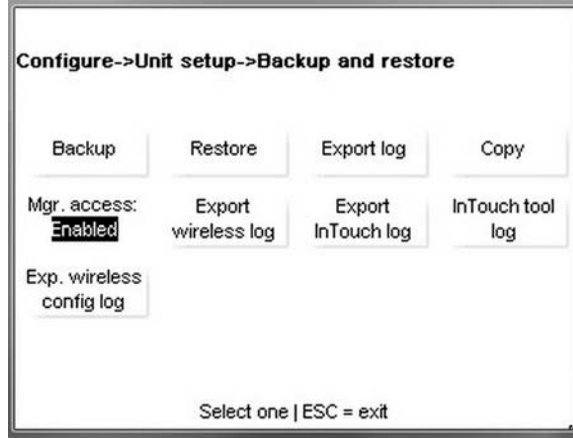

Backup

First select the Drive for the backup: internal Flash or external USB.

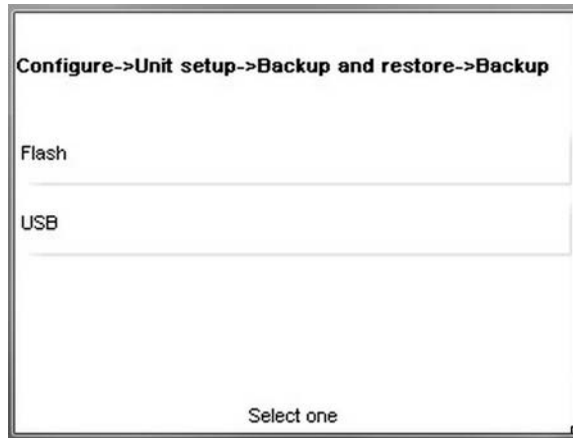

For this example, USB is selected. If there is a folder, navigate to the folder and touch "Open".

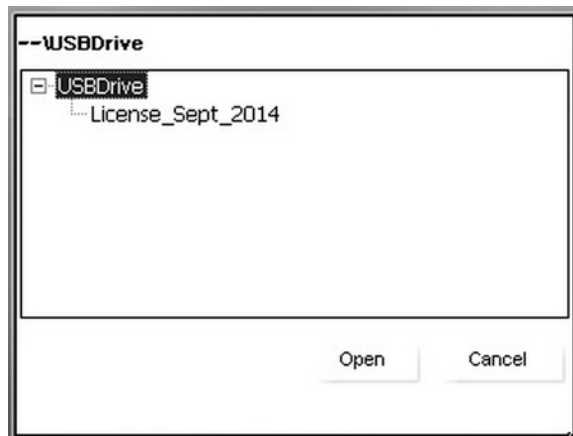

Select the Configuration Data to back up by touching the "Configuration Data" line on the menu.

Configure->Unit setup->Backup and restore->Backup ->USB

Configuration data

Database

Enter package name

Backup

Select,edit | select | ESC = exit

Select Configuration data by touching "No" to toggle it to "Yes". Press the Enter button on the keypad when done selecting.

Configure->Unit setup->Backup and restore->Backup ->USB

Accumulator	No
Application	No
Barcode	No
Calibration	No

Sele

Configure->Unit setup->Backup and restore->Backup ->USB

Grade	No
Label settings	No
Network	No
Printer	No

Sele

Configure->Unit setup->Backup and restore->Backup ->USB

Wireless	No
Transaction	No
Label formats	No
Department address	No

Select options | <J = accept | ESC = cancel

Next, select the Database Data to back up by touching the line and toggling the data type to Yes.

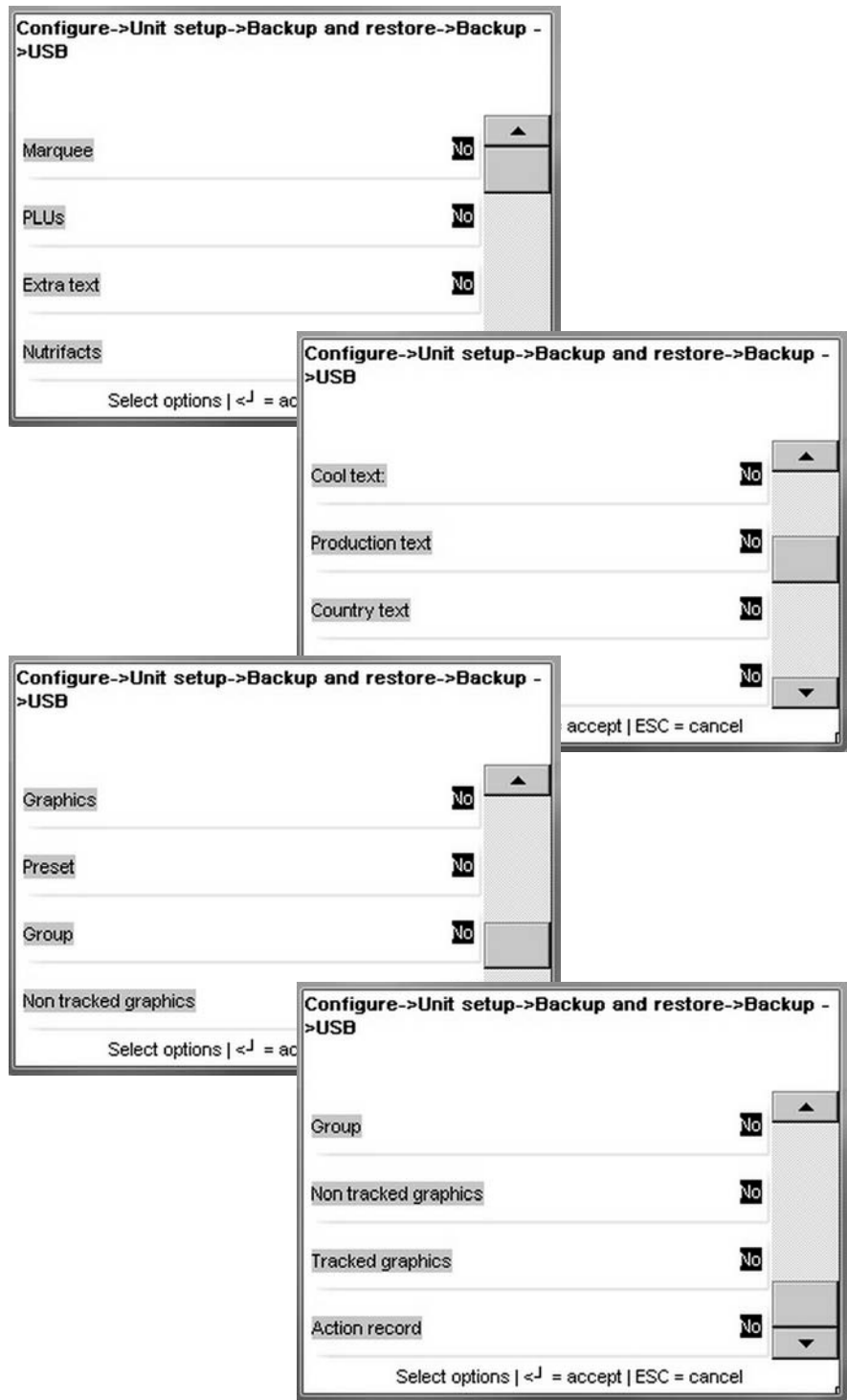

Press the Enter button on the keypad to accept the data types to back up.

Touch "Enter Package Name" to type the file name for the backup.

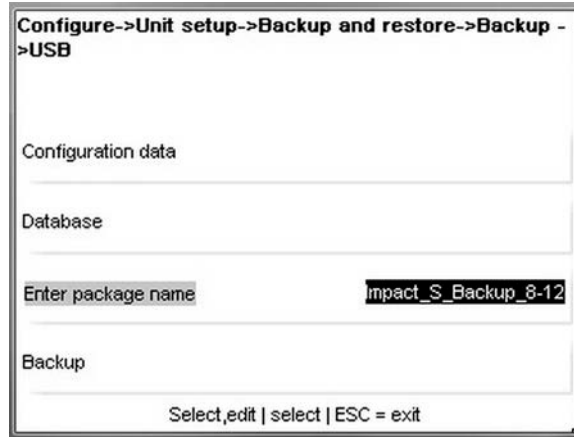

Touch "Backup" to start. The screen will display a status message while the backup is in process. Do not remove the USB drive until the backup completes. A message will display indicating the backup has finished. When complete, touch the Ok button on the screen. The USB drive can then be removed from the Impact S.

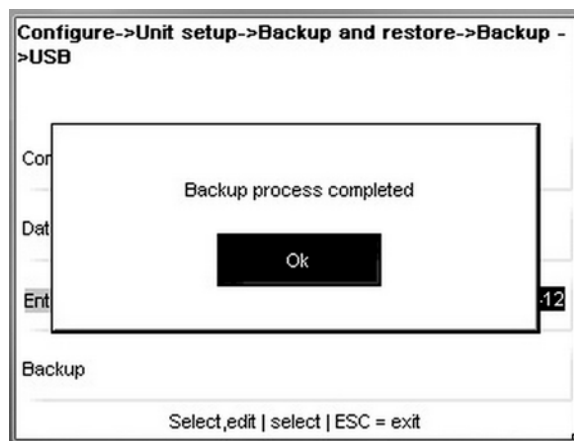

Restore

Restore is used to copy a previous backup and over-write current data with the new data. First select Flash or USB.

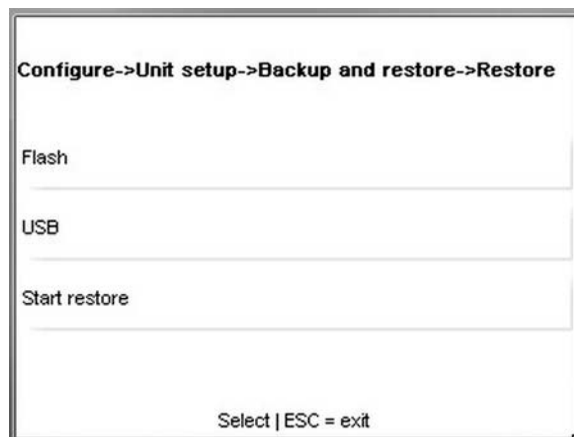

For this example, an external USB drive is used that contains a previous backup set.

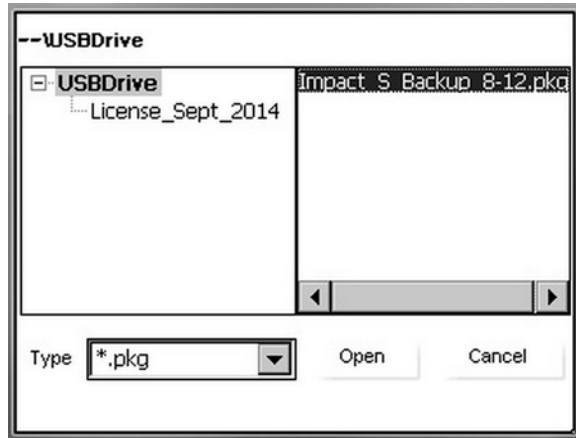

Touch the file and the Open button on the screen.

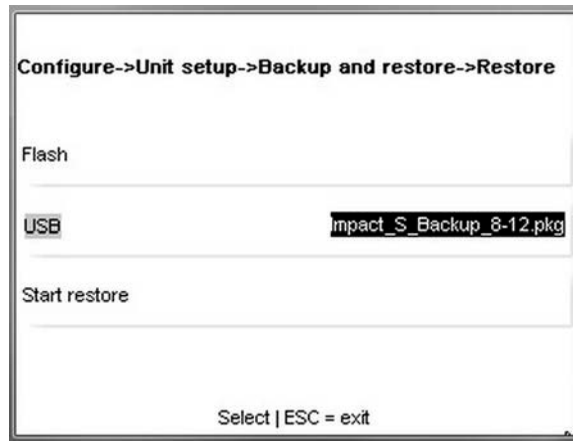

Touch "Start Restore" to start the restore process. When complete a message will display indicating whether the restore was successful or not. If the files are restored without problems, exit the screen using the ESC button on the keypad. The USB drive can then be removed from the Impact USB port.

Copy

Copy is used to copy files to or from the Impact S. First select the source file and then the destination. Touch Copy on the screen to start copying the files. When complete, the Copy Complete message will display.

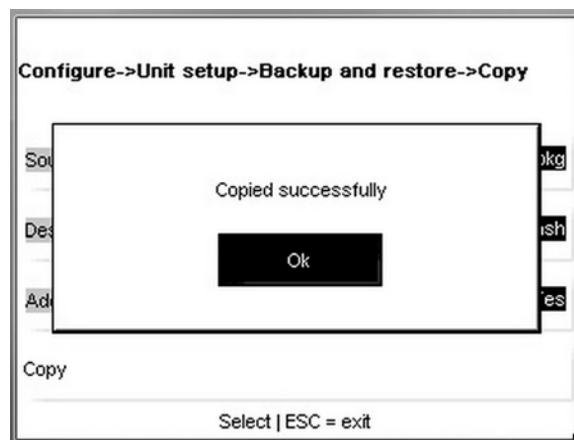
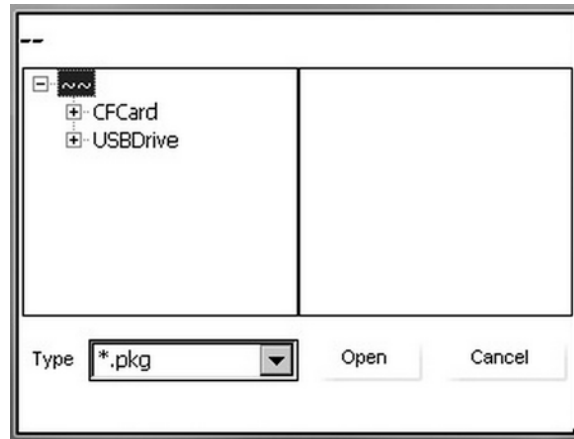
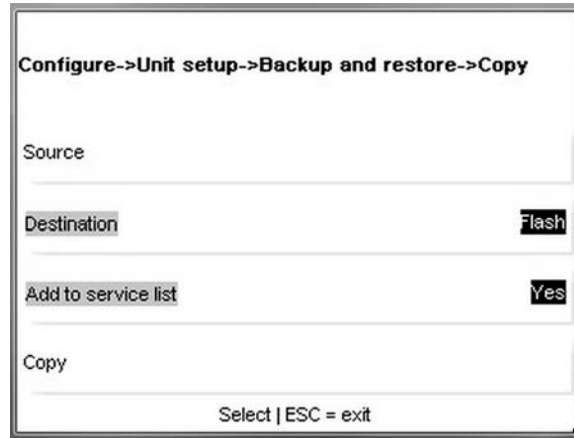

Export Logs

Export logs is sometimes used for troubleshooting problem areas. The export function will store the log files on the Impact under the Service\Log folder.

Scale Settings

Entering the **Scale Settings** menu allows the user to change many of the most basic usability and functionality settings of the unit.

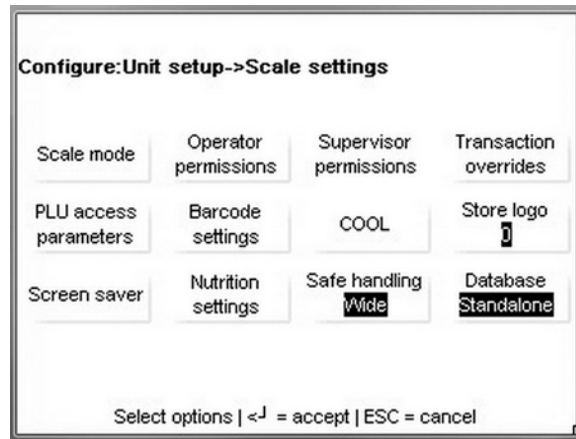

Scale Mode – Select Service or PrePack mode and Service/Prepack Mode Key behavior.

Operator Permissions – set permissions for a unit operator.

Supervisor Permissions – set permissions for the unit supervisor.

Transaction Overrides – Choose which fields can be changed on the transaction screen

PLU Access Parameters – Configure how PLU number call up works and certain transaction functions.

Barcode Settings – choose the printed barcode format.

COOL – activate, disable or modify the country of origin labeling for the unit.

Store Logo – Select a graphical logo for the printed labels.

Screen Saver – Select a series of graphic images to display as a time-out screen saver.

Nutrition Settings – Configure the nutritional information data printing.

Safe Handling – Select normal or wide format.

Database – Select Standalone or Client mode database operation.

Scale Mode

Scale Mode selects how the scale will operate when calling PLUs and how it will print labels. Choose Service or Prepack and then set the appropriate print activities from the corresponding menus. Service clears the PLU after the transaction. Prepack retains the PLU information until clear is pressed and will automatically print a label whenever an item is placed on the platter. Press the **ENTER** button on the keypad when finished.

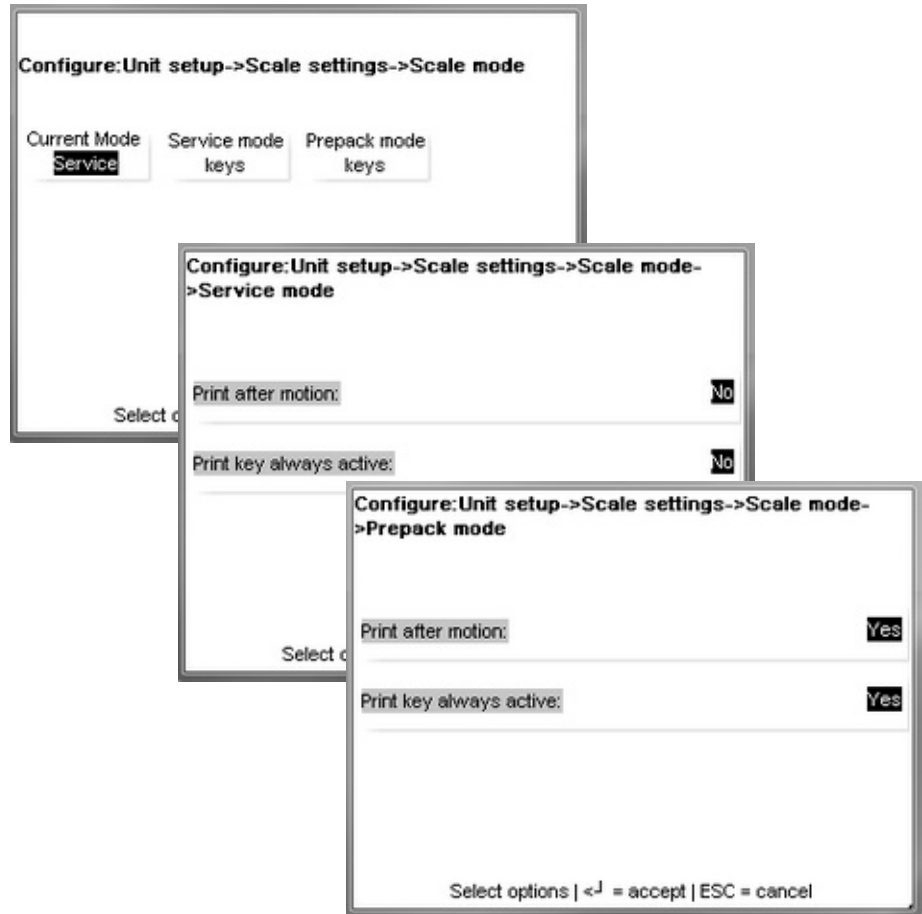

Operator Permissions

The **Operator Permissions** menu enables or disables functions available to an operator of the Impact S. These include items such as: **Memory Mode**, **Batch Queue**, different **Totals** tracking, and **Voids**. Press the **Enter** button on the keypad to save and exit when done.

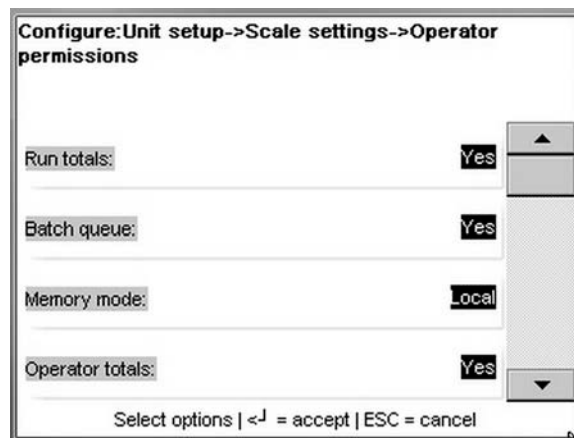

Configure:Unit setup->Scale settings->Operator permissions

By count auto clear:	Yes	▲
Void	Enabled	■
Operator set time and date flag:	Enabled	■
Operator change department flag:	Enabled	▼

Select options | <J = accept | ESC = cancel

Configure:Unit setup->Scale settings->Operator permissions

Keyboard tare:	Enabled	▲
Operator select quick edit flag:	Enabled	■
Operator select preset setup flag:	Enabled	■
Operator Screen Scale Identifier	P address	▼

Select options | <J = accept | ESC = cancel

Configure:Unit setup->Scale settings->Operator permissions

Operator select language flag:	Enabled	▲
Operator select label printer flag:	Enabled	■
Operator select home screen setup flag:	Enabled	■
Platter tare:	Enabled	▼

Select options | <J = accept | ESC = cancel

Supervisor Permissions

Similar to the **Operator Permissions** menu, the **Supervisor Permissions** menu allows another supervisor (normal operators are denied access to this menu) or technician to modify the fields and menus available to the unit supervisors. Toggle the choices by pressing the appropriate line and press **ENTER** when satisfied.

Transaction Overrides

This menu allows specifies which fields over-riden by an operator of the scale. Press the **ENTER** button on the keypad to save changes.

Configure:Unit setup->Scale settings->Transaction overrides

Modify pack date:	Yes
Modify sellby date:	Yes
Modify useby date:	Yes
Modify net wgt:	Yes

Select o

Configure:Unit setup->Scale settings->Transaction overrides

Modify price:	Yes
Modify tare:	Yes
Modify count:	Yes
Grade:	Yes

Select o

Configure:Unit setup->Scale settings->Transaction overrides

Modify label format:	No
Modify extra text:	Yes
Modify nutrifact:	No
Override by count / std. pack total price:	Yes

Select options | <J = accept | ESC = cancel

PLU Access Parameters

This menu configures how the scale reacts when entering a PLU number.

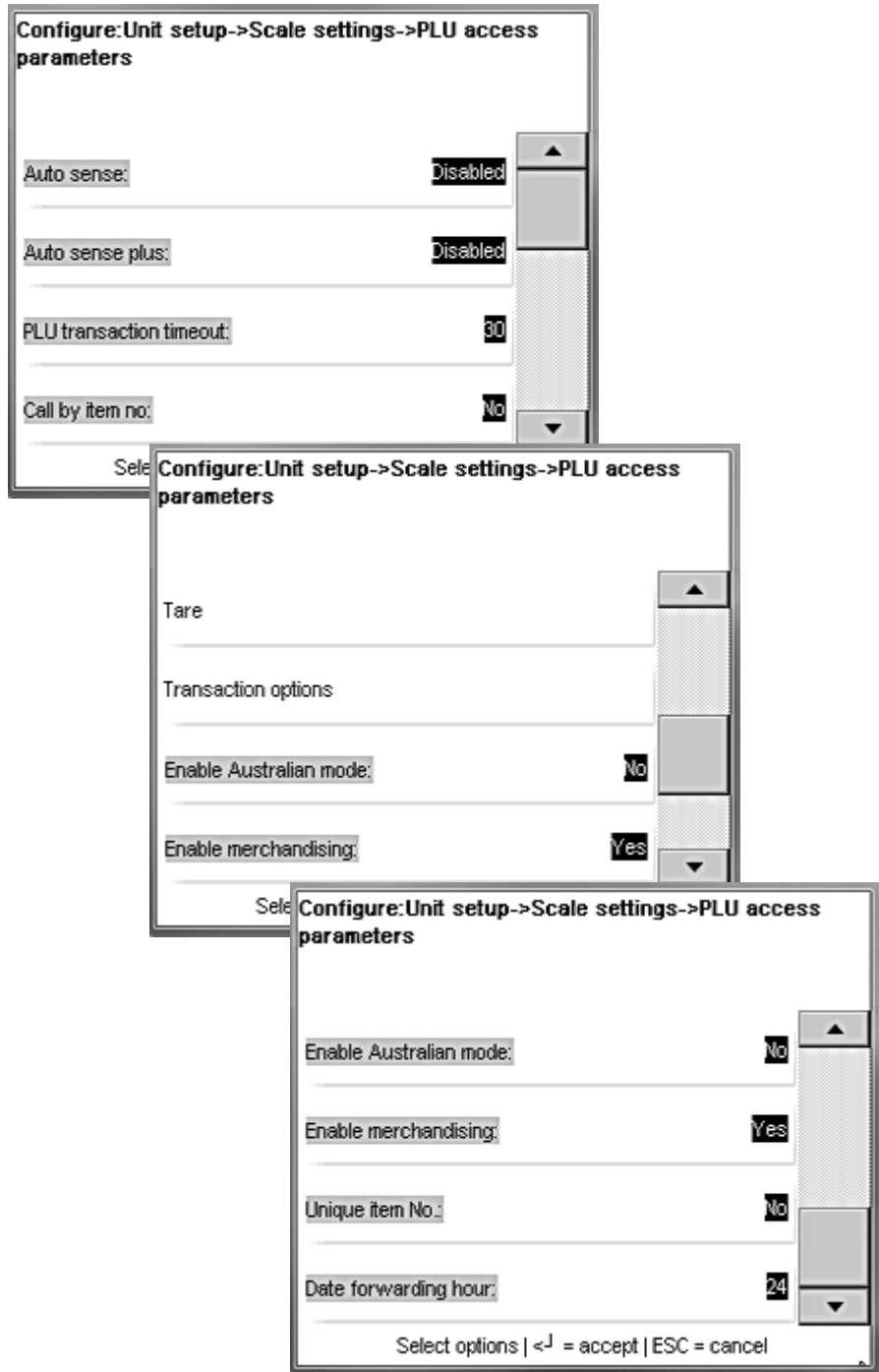

Auto Sense - the scale will automatically call the PLU without the need to press the Enter key. For example, if the PLUs are 4-digit and Auto Sense is set to four digits, when the 4th digit is pressed, the PLU will be called without pressing Enter to complete the entry.

Auto Sense Plus - When Auto Sense is not disabled, the value entered is automatically ignored by Auto Sense when it is the leading digit of the PLU number entered. Example 1: If Auto Sense is disabled and 9123 is entered, PLU 9123 will be called (even if what you are trying to enter is 91234). Example 2: If Auto Sense Plus = 9, Auto Sense = 4, and 91234 is entered, PLU 1234 will be called; the 9 will be ignored.

PLU Transaction Timeout – The time in seconds of inactivity when the scale will return to the main menu. Select from Disabled, 15, 30, 45, 60, 75, 90, 105, and 120 seconds.

Call by Item Number – When this is set to Yes, item records will be called by the Item Number (UPC number).

Tare – When touched, the following options will display.

- Tare Field – Select the tare field to use as a default, None, Tare1, Tare2, Tare3, or Tare 4.
- Proportional Tare – Yes or No. Yes to enable, or No (default) to disable proportional tare. If Proportional Tare is used, it is stored in the Tare2 field. By-Weight tares are stored in the Tare1 field. The Net Weight will be the gross weight minus the By-Weight Tare, minus the proportional tare, times the Gross Weight, minus By-Weight Tare value. The mathematical representation is as follows:
$$\text{Net Weight} = (\text{Gross Wgt} - \text{Tare 1}) - (\text{Tare 2} \times (\text{Gross Wgt} - \text{Tare 1}))$$

Transaction Options – The following menu will display when this button is pressed.

- **Memory Mode Print Individual Label** – Yes will print a separate label for each item in memory mode. No will print a totals label for all items.
- **Allow Future Pack Date** – YES allows the operator to change the pack date. NO prohibits the operator from changing the date.
- **Mixed Net Weight Statement** – When set to YES, the net weight printed on the label will be in lb (kg) or kg (lb). When set to NO, the net weight printed on the label will be in oz (lb) or oz (kg).
- **Barcode Priority** – Sets the priority of the bar code. When set to "PLU record, scale settings" the PLU record bar code type will over-ride the local scale settings. When set to "Scale Settings", the bar code will not be over-riden by the PLU record settings.

Enable Australian Mode - Default is NO for standard tare operation. YES selects the following (required for units sold in Australia):

- Disables preprogrammed tare.
- By-Count PLUs are not allowed.
- Fractional or "kg For" pricing is not allowed.
- Enables increasing tare requirement. (The next platter tare taken must be higher than the value on the display.)
- For Australia, also set the option tare field to use to NONE.

Enable Merchandising – Default is No. With a license key, Yes allows use of large label graphics.

Unique Item No. – Default is no. When set to Yes, the same item number can be used for multiple PLU numbers.

Date Forwarding Hour – Default is 24. This is the hour after which the "Pack Date" will be incremented.

Barcode Settings

Configure the bar code symbols that will print on the Impact S.

Bar Code Format Codes:

- N Item number Digits.
- C Check Digit.
- 0 The number zero.
- \$ Total Price Digits.
- # Weight Digits.
- X Symbol Check Digit.

- 0 Type 0 Prefix (No price is encoded)
- 1 Type 1 Prefix (No price is encoded)
- 2 Type 2 Random-Weight, price encoded.
- 3 Type 3 Prefix (No price is encoded)
- 4 Type 4 Prefix (No price is encoded)
- 5 Type 5 Prefix (No price is encoded)
- 6 Type 6 Prefix (No price is encoded)
- 7 Type 7 Prefix (No price is encoded)
- 8 Type 8 Prefix (No price is encoded)
- 9 Type 9 Prefix (No price is encoded)

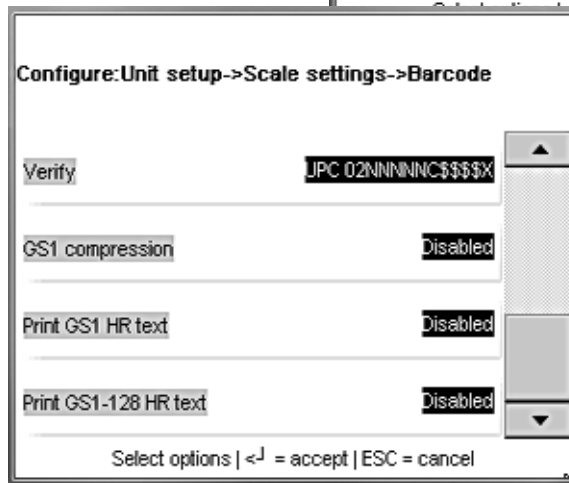
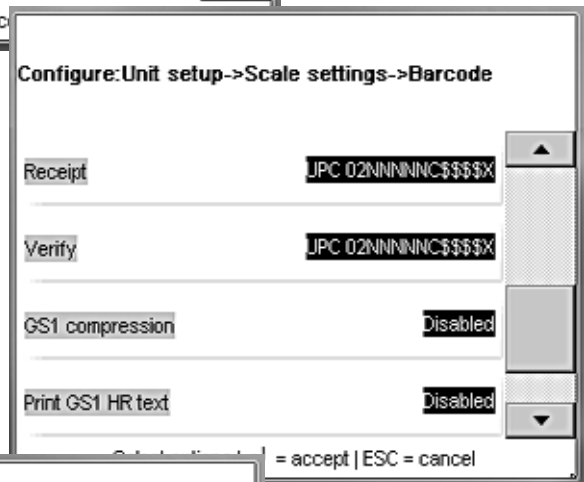
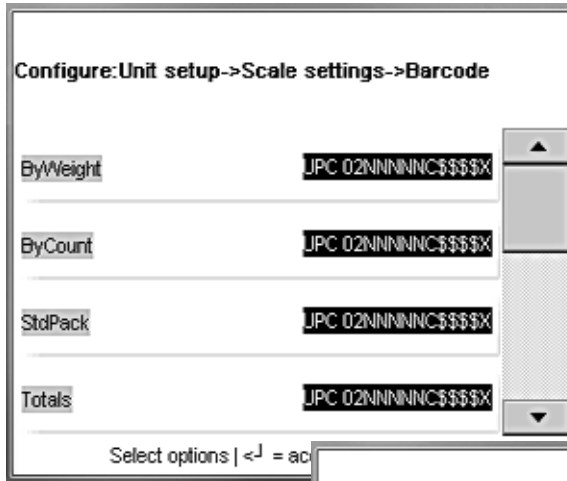

GS1 compression - compresses the GS1 Databar and makes it smaller (a 2D scanner is required)

Print GS1 HR Text option - Enable the Print GS1 HR Text option if you would like to print the Human Readable Text

Press **ENTER** when finished.

COOL

The **COOL Options** configures various aspects of COOL (country of origin labeling) for printing on labels.

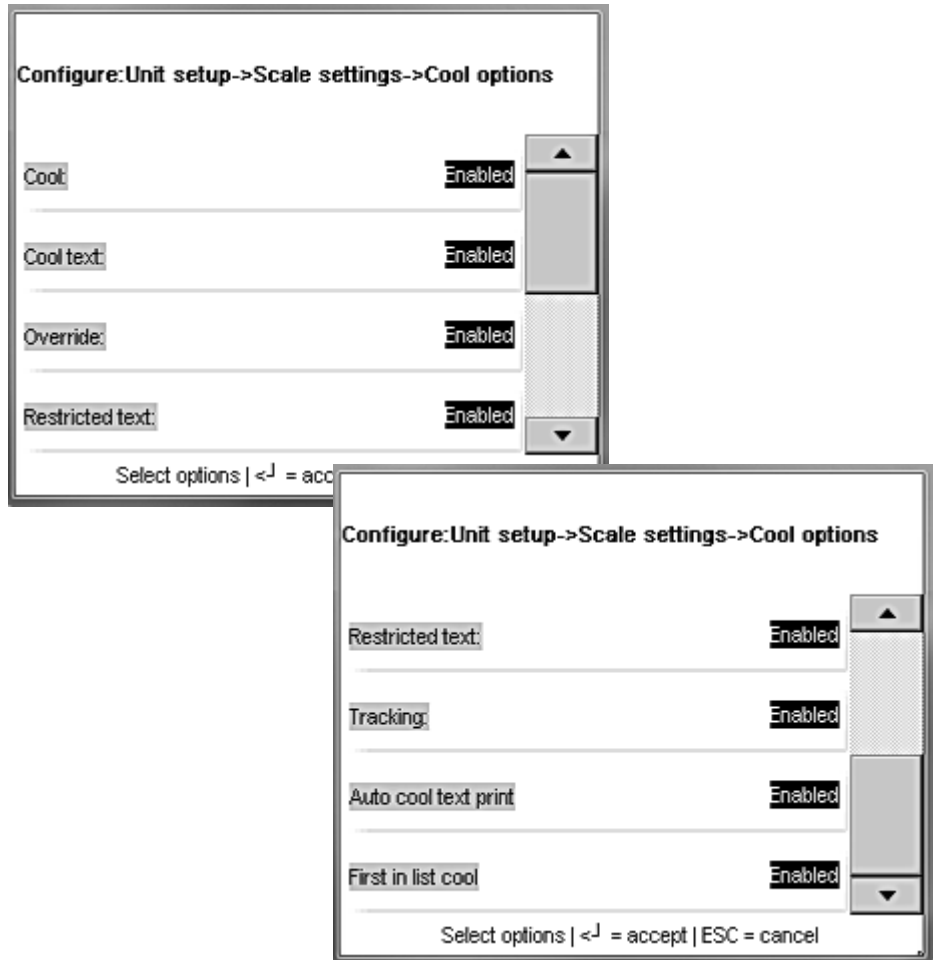

COOL Text

Enable allows an override from the PLU screen. Disable displays data, but touch box is not active for overrides.

Override

Enable allows COOL to be canceled or overridden by the operator. Disable prevents overrides and the "No COOL" key will not be displayed.

Restricted Text

This setting governs the way the COOL screens are presented and how it operates.

Disabled - When set to Disabled and Force COOL = YES in the PLU record, the operator is required to manually select a COOL text and press the ENTER key to accept. Optionally, if OVERRIDE FORCED COOL is set to Enabled, the default COOL text can be changed by selecting another COOL text or by selecting a Custom COOL text. The setting in the PLU record Force COOL must be set to YES for this feature to work. Maximum length of text is limited to 150 characters.

Enabled - When set to Enabled, the last used COOL text is automatically highlighted and if no change is required, the ENTER key will accept the displayed COOL text. Optionally, if OVERRIDE FORCED COOL is set to Enabled, the default COOL text can be changed by selecting another COOL text or by selecting a Custom COOL text.

Some other notes when using Restrict COOL Text Mode:

- Operator must always make a selection of COOL Text.
- If changing the default text, the operator will be presented with a message verifying the choice.
- Last selection on Custom COOL must be a country.
- Text wrapping shows up different on the screen.
- Maximum length of text is limited to 110 characters.
- Date format changes.

Tracking

The tracking feature can be used to enter an additional number or code to a specific product or vendor.

Auto COOL Text Print

When this is set to Enabled, the default COOL statement is printed without operator input. The operator has the option of overriding the default manually.

First in List COOL

When this is set to Enabled, the default COOL statement is the MRU (Most Recently Used). When the MRU is blank, the first-in-list is the default. When set to Disabled, the first-in-list is the default. This is used only when the Auto COOL Text Print is set to Enabled.

Store Logo

Select the image for the store logo. The store logo images must already be loaded in the unit database. The store logo is used to print on label formats that have this field configured in the format. The images for the store logo must be added using SmartX. The size (in pixels) for the images will depend on the label size in use. Standard labels with a width of 2.64" at 8/dots mm will be around 240 pixels for the full width of the labels.

Screen Saver

Displays images in a slideshow-style viewing.

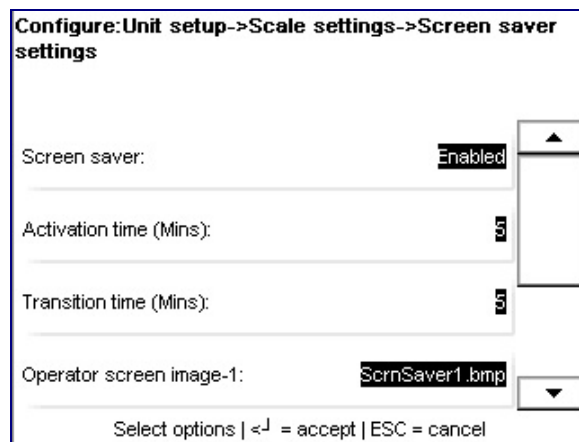

To add new files, refer to the Backup/Restore section on how to copy files.

Nutrition Settings

Configure the nutrition information settings according the needs and labeling requirements for the location the scale is in.

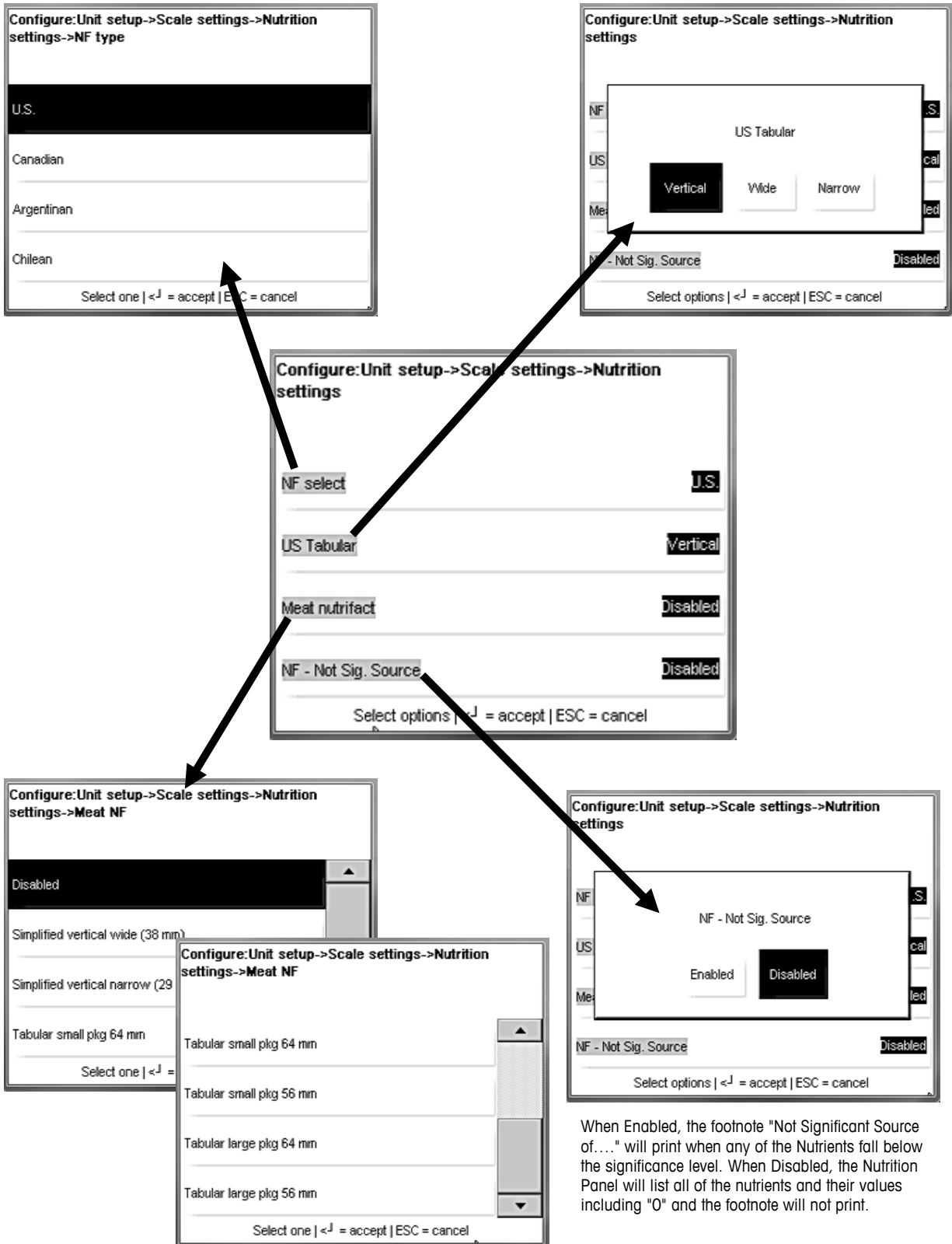

When Enabled, the footnote "Not Significant Source of..." will print when any of the Nutrients fall below the significance level. When Disabled, the Nutrition Panel will list all of the nutrients and their values including "0" and the footnote will not print.

Safe Handling

Select the Safe Handling graphic to use when printing labels.

In order to print Safe Handling graphics, the label style must contain the Safe Handling Graphic field. Some standard formats contain the field and a custom style can be created. Refer to label styles for more information.

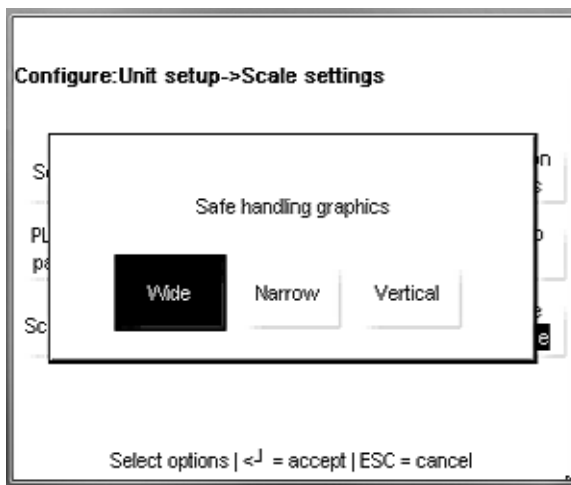

Safe Handling Graphic - Narrow

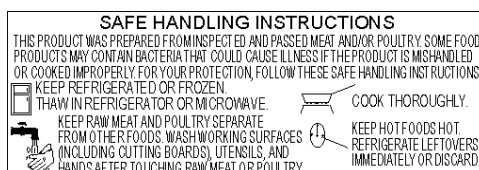

Safe Handling Graphic - Wide

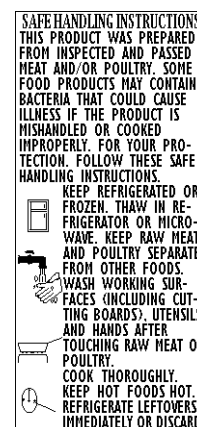

Safe Handling Graphic - Vertical

Database

The Impact S can operate as a standalone unit with an internal database or as a client connected on a network to a STEM (SmartTouch Ethernet Master) – a networked hub that holds PLU data. Standalone is the scale default setting. For Client mode, press the Client button. The scale must be restarted for the change to take effect.

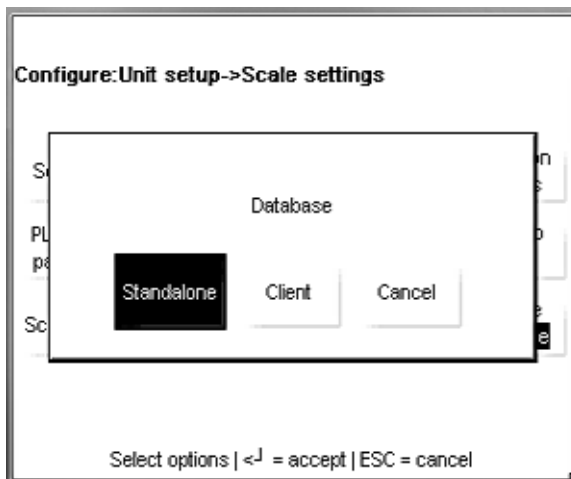

Communication

The **Communications** menu is used to configure the network communication, Wi-Fi, and email parameters of the scale.

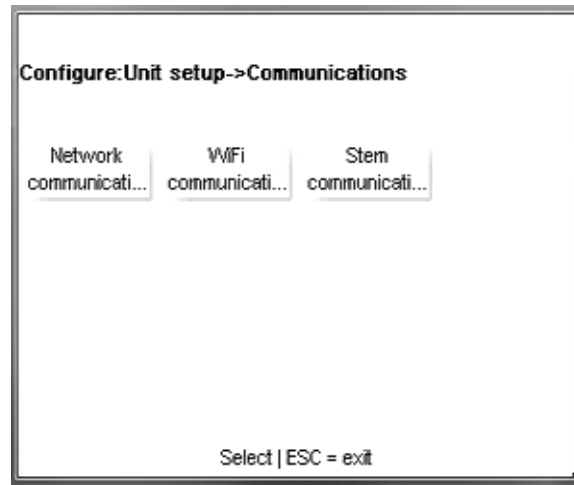

Network Communications

Network Communications is a menu that allows the user to adjust and view the different network parameters currently implemented.

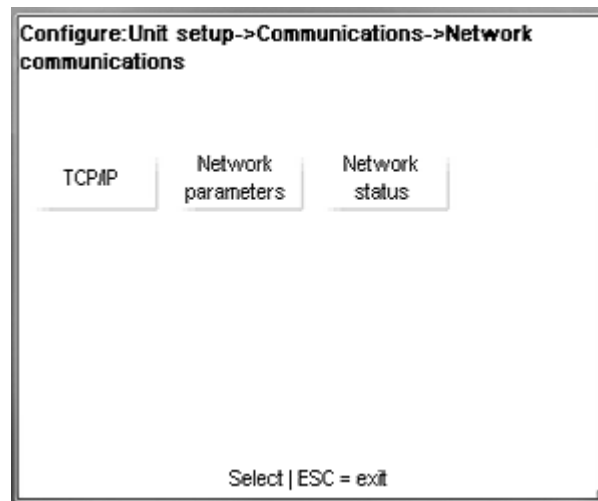

TCP/IP – Edit the name and IP addresses of the networked unit, enable or disable DHCP (the default setting is **Disabled**).

Configure: Unit setup->Communications->Network communication->TCP/IP

Name:	DLA-33
DHCP:	Enabled
IP addr:	172.018.049.089
Subnet:	255.255.252.000

Select options | <J = accept | ESC = cancel

Configure: Unit setup->Communications->Network communication->TCP/IP

Router:	172.018.048.001
DNS1:	172.018.033.050
DNS2:	000.000.000.000
Server	172.018.048.023

Select options | <J = accept | ESC = cancel

Network Parameters – Edit the parameters of the network’s connectivity (like the **Time Sync Server** or **Host Communications Port**).

Configure:Unit setup->Communications->Network communication->Network parameters

Mac addr:	00-10-52-c0-4d-fd
WinCE NTP service:	Enabled
NTP IP:	000.000.000.000
Scale port	2305

Select options | <J = accept | ESC = cancel

Configure:Unit setup->Communications->Network communication->Network parameters

ARP frequency(mins):	15
Timeout(secs):	180
Directed ping IP:	172.018.048.001
Directed ping interval(mins):	Disabled

Select options | <J = accept | ESC = cancel

Configure:Unit setup->Communications->Network communication->Network parameters

Timeout(secs):	180
Directed ping IP:	172.018.048.001
Directed ping interval(mins):	Disabled
NIC restart delay(mins):	Disabled

Select options | <J = accept | ESC = cancel

Network Status – used to check the online status of other scales or devices on the network. Press the **Test Ping** button, key in an IP address and press the **Enter** button on the keypad. A window will display with the results of the test.

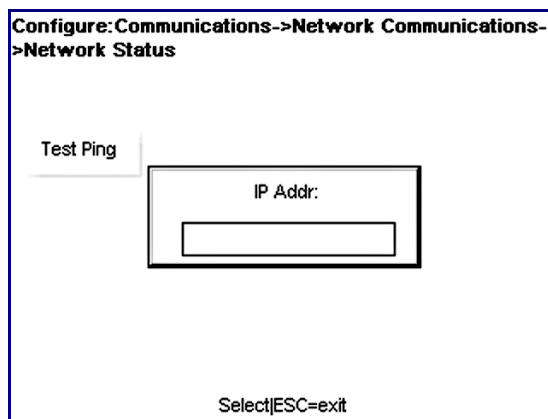
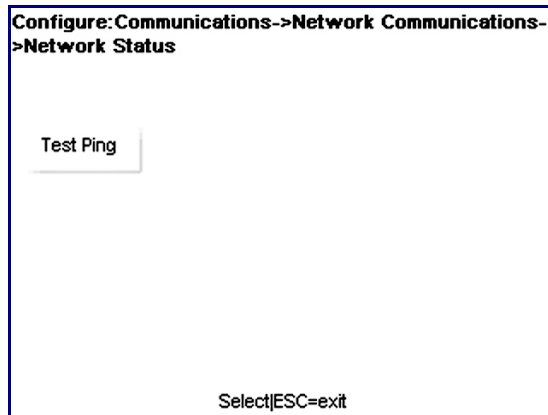

WiFi Communications

This menu will configure the scale's wireless controller. Select the Wireless Adapter Type and select from Auto, MTWA4 (Dolphin wireless), MTWA5 (Quatech), or WGB3 (3Com Work Group Bridge).

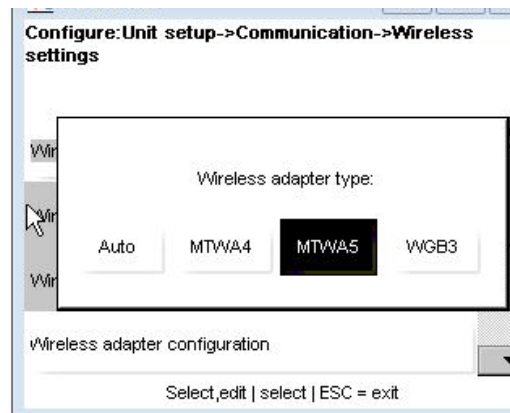
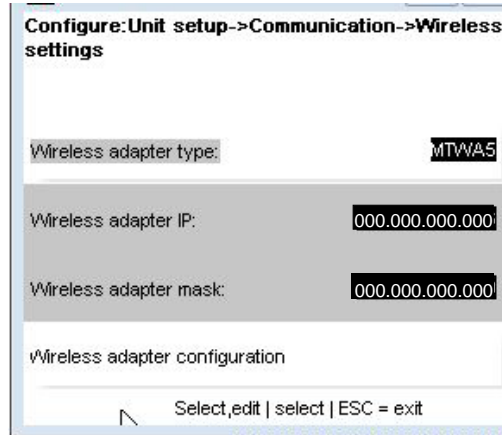

Select "Wireless adapter configuration" to set up the wireless network configuration. Below are the settings that are configurable:

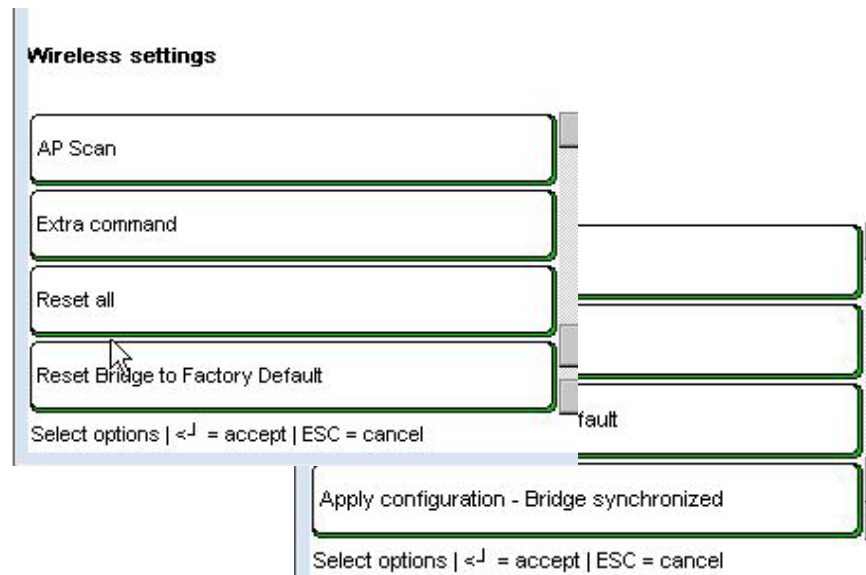
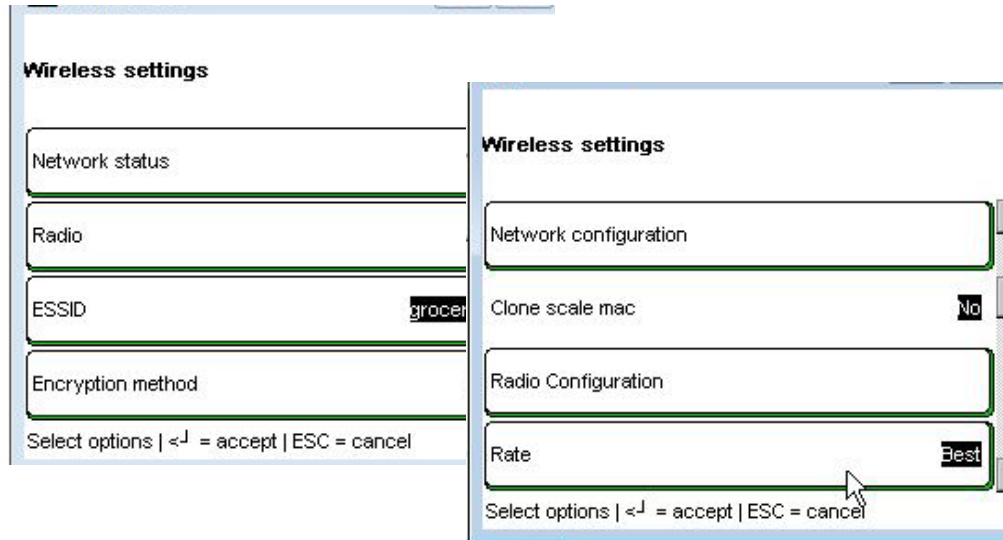

Encryption Method – Set the wireless encryption method used to connect to the network. Encryption options include none, WEP, WEP-LEAP, WPA, and WPA2.

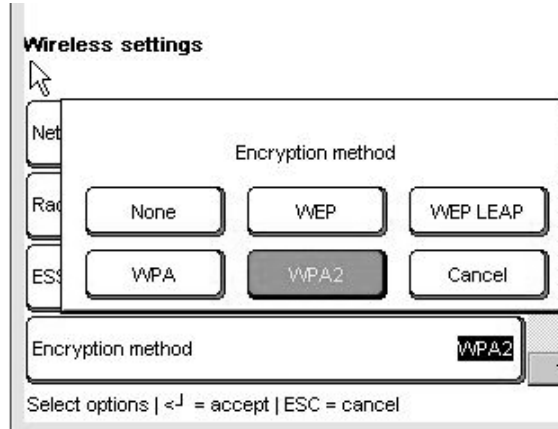

Network Configuration:

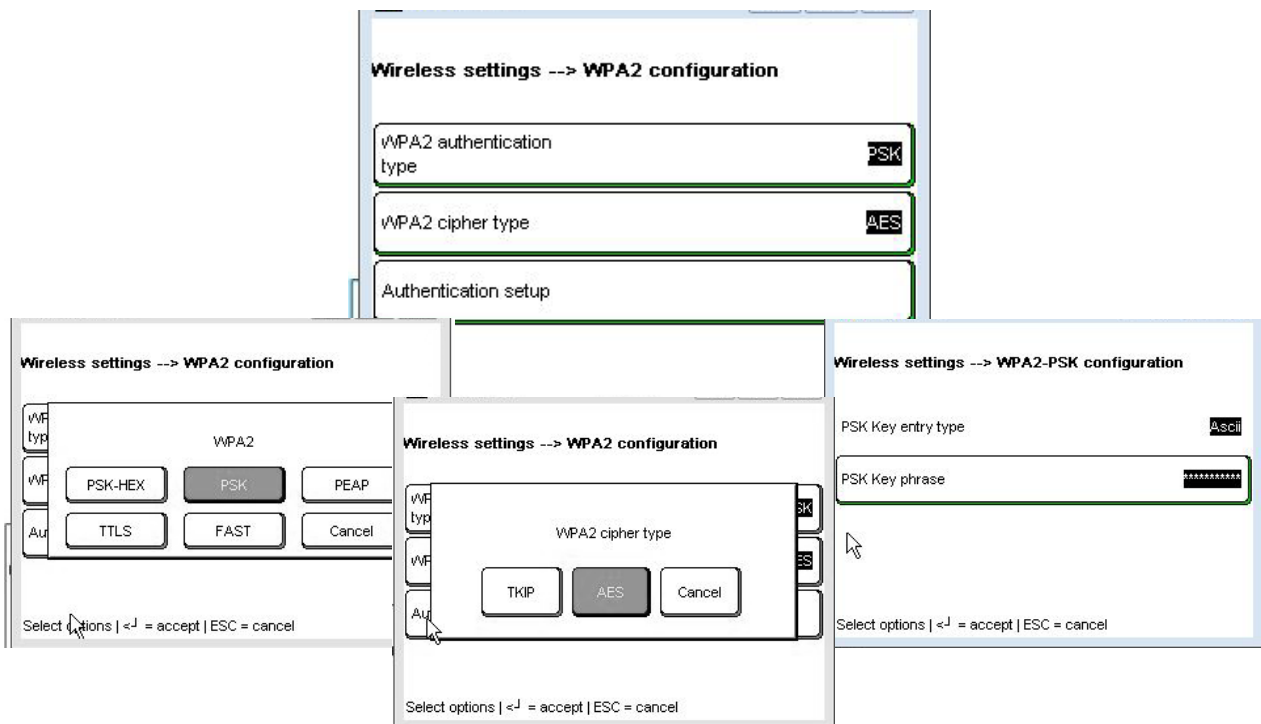

AP Scan – Shows active APs, their frequency, and call strength in the area.

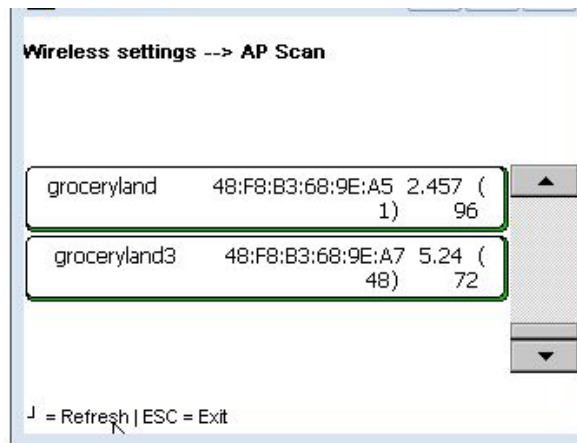

Select Apply configuration – Bridge synchronized to save changes.

Screen Calibration

If needed, the screen touch accuracy can be re-calibrated. There is a built-in timeout in case the function is accidentally selected. When the timer counts to zero, the scale will return to the **Configure** main screen.

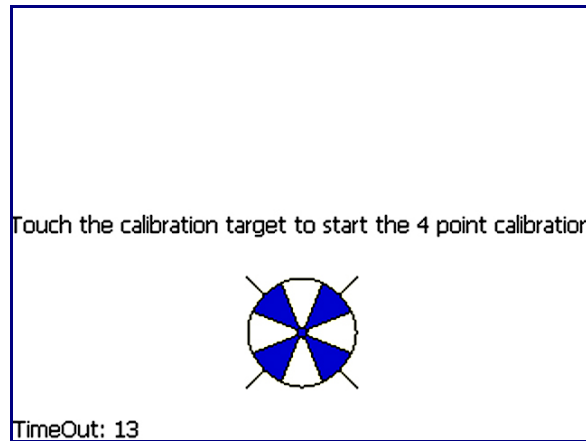

Touch the center of the circular graphics as they appear, waiting until they shrink to a small point and you are prompted to let them go. For added precision, use the tip of a stylus.

When finished, you will be presented with the option of moving your finger around to ensure realistic tracking of the on-screen pointer. Press **Accept** to complete calibration.

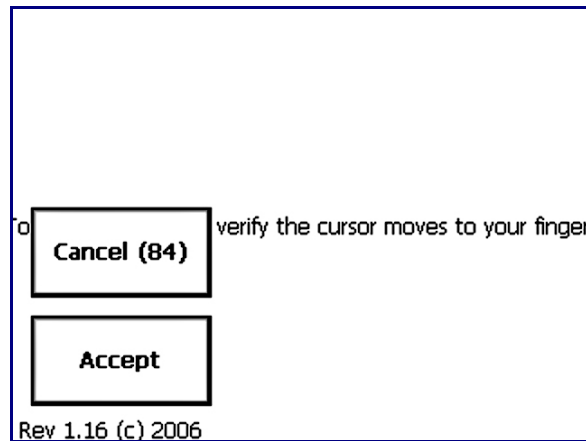

Set Home Screen

This setting determines which screen will come up when the unit is first booted. Any of the preset pages can be chosen.



Technician

The password protected **Technician** menu allows access to functions such as calibration of the unit, backup of the system data, as well as resetting of the unit. Refer to the Impact S Service Manual for details.

Select Department

Select the default department for the PLU database.

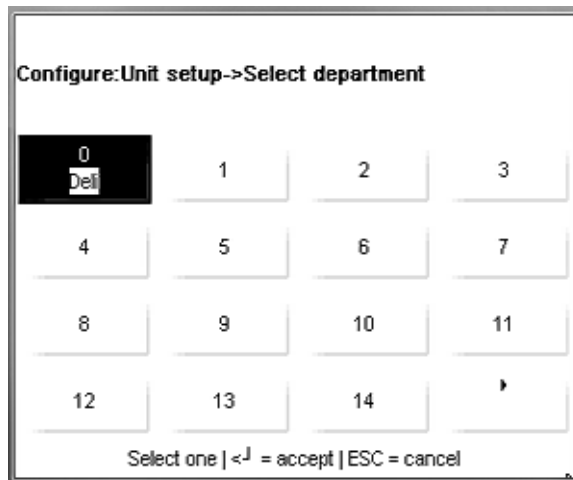

Printer Setup

The **Printer Setup** menu is used to configure the printer and labels.

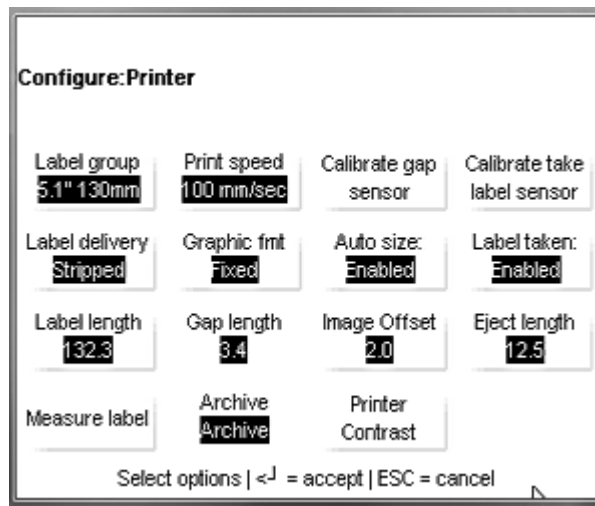

Label Group – press to select from a list of available label sizes

Print Speed – press to select from a list of print speeds

Calibrate Gap Sensor – press button to calibrate sensor. Multiple labels will print

Calibrate Take Label Sensor – press button to calibrate sensor. Multiple labels will print

Label Delivery – toggle between "Stripped" and "Unstripped"

Graphic Format – this selection is for continuous label stock, toggle.

Auto Size – toggle between "Enabled" and "Disabled". Enabling auto size matches a label group to the current label stock after the unit measures it upon printing.

Label taken – toggle between "Enabled" and "Disabled"

Label Length – select to type in specific label lengths. **Measure Label** will override.

Gap length – select to type in specific gap lengths. **Calibrate Gap Sensor** will override.

Image Offset – select to type in specific offset to start label from top

Eject Length – select to type in specific eject length of label when complete

Measure Label – press to have the unit measure the existing label stock. Multiple labels will print

Archive – xxx

Printer Contrast – Set the printer contrast.

Label Group

Label Group selects the available label sizes. Touch to select the field and press **Enter** to accept.

Configure: Printer->Label Group

2.4" 60mm

3.3" 84mm

3.7" 94mm

4.2" 107mm

Select one | <J = accept | ESC = cancel

Print Speed

Select the printing speed. The default is 100.

Configure: Printer->Speed

125 mm/sec 100 mm/sec 90 mm/sec 80 mm/sec

70 mm/sec 60 mm/sec

Select one|Enter=accept|ESC=cancel

Calibrate Gap Sensor

For label indexing problems, first try cleaning the Gap Sensor (see cleaning section). After cleaning run this sensor calibration. Labels will eject while the sensor is calibrated.

Calibrate Take Label Sensor

The Take Label Sensor detects if a printed and ejected label is still on the printer. The label must be removed before the next prints. If problems are encountered with this sensor, first clean any label dust or debris from the lens and then run this calibration procedure.

Label Delivery

Select Stripped or Unstripped label delivery. Stripped mode peels the label from the liner. Unstripped leaves the label on the liner and is used for multiple label printing.

Graphic Format

Allows for flexibility in the printing of graphics on a per-label basis via modification of the continuous label stock toggle.

Auto Size

Enables the auto setup of the "Label Size" selection after a label is measured.

Label Taken

Enables or disables the label taken sensor. Important for batch-processing of labels.

Label Length, Gap Length, Image Offset, Eject Length

These four functions are used for label indexing and print adjustment.

Label Length – Sets the label length (mm).

Gap length – Specifies the gap, in millimeters, between two labels.

Image Offset – Moves the print up or down on the label.

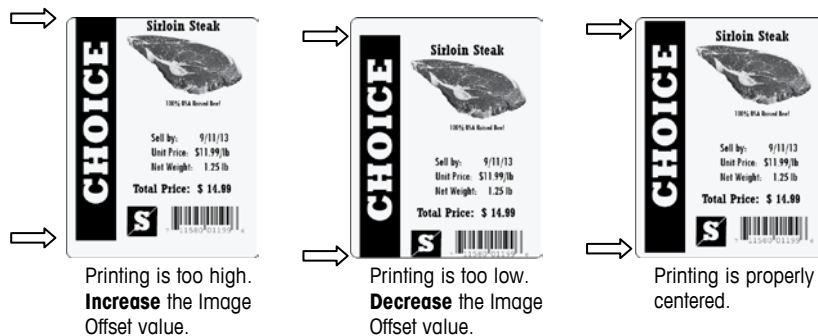

Eject Length – The length in millimeters for the label to feed out of the printer so stripped labels are easily removed but without falling to the floor. Also insures the label has fed out far enough to clear all printed material before tear-off of continuous stock. A higher value will move the label farther out of the printer and a lower back into the printer.

Measure Label

This function will measure the label stock and will automatically overwrite any current settings. The printer will feed out several labels while determining the length of the labels.

Printer Contrast

Adjusts the print density lighter or darker. Adjustment range is from 0 (lightest) to 8 (darkest). The default is 4.

Security

The Security button is a toggle that activates and deactivates the security. To allow full access by all users, toggle this field to **Disabled**. Touch again to turn on security by displaying Enabled.

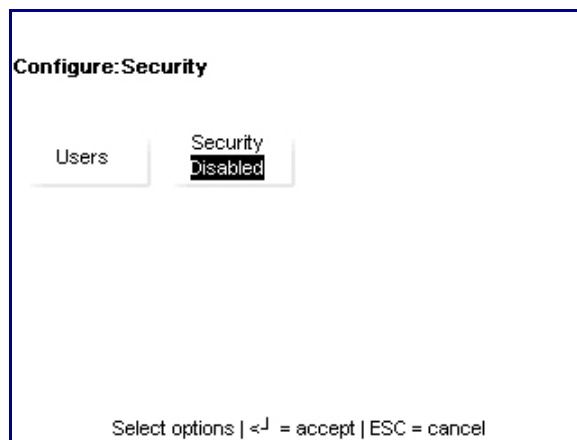

Users – Add or edit the permissions of users. Four levels can be defined:

- 1.) Operator – has access to transaction screens only. No permission to access setup menu when security is enabled
- 2.) Supervisor – has access to transactions and item database setup menus. No permission to access weights and measures significant parameters.
- 3.) Manager – has access to all supervisor-class screens/menus as well as scale setup menus.
- 4.) Technician – has access to all screens, including full setup and calibration menus.

Security – this field is a toggle that switches between "Enabled" and "Disabled" for the scale. Only Managers and Technicians can change this state.

Users may take advantage of/edit/create at any level of the system that is equal to or lower than their own. For example, a Technician can modify anything a Manager, Supervisor or normal Operator can, but a Supervisor may only modify his own set of screens and any of the Operator screens.

Users

The **Users** button is used to add, modify, or delete users.

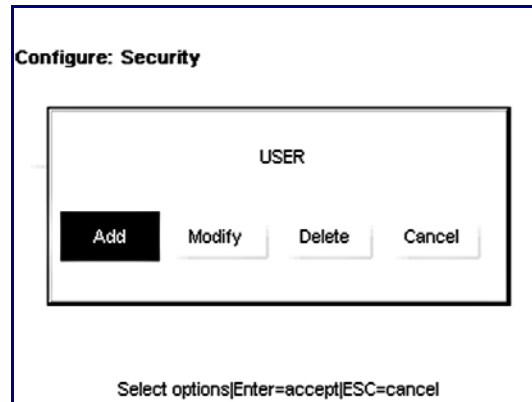

For example, to add a new user into the system, press the Add button to bring up the following menu.

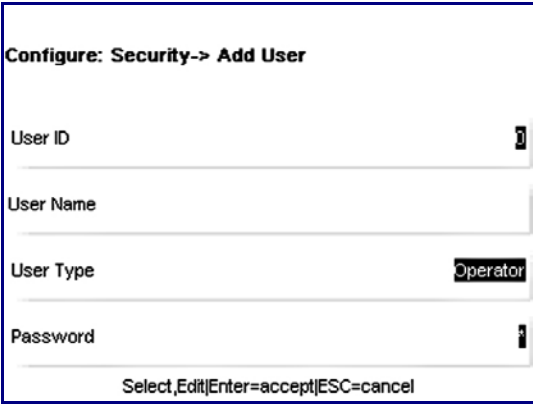

The screenshot shows a terminal window titled "Configure: Security-> Add User". It contains four input fields: "User ID", "User Name", "User Type", and "Password". The "User Type" field has "Operator" selected. Below the fields, the text "Select,Edit|Enter=accept|ESC=cancel" is displayed.

Input an ID number, a user name and a password number and select the access level – operator, technician or supervisor. Press **Enter** when finished.

- 1.) Operators have no access to setup menus (no password required, obviously)
- 2.) Supervisors cannot create/edit a technician's permissions – just other supervisors and operators. Password protected (passwords must be between 2 and 9 characters long)
- 3.) Managers can create/edit permissions for all but Technicians. Password protected.
- 4.) Technicians can alter anyone's permissions. Password protected.

System Status

The **System Status** menu is particularly useful for determining version information, setting the comprehensiveness of the **Log** function and viewing the existing logged data.

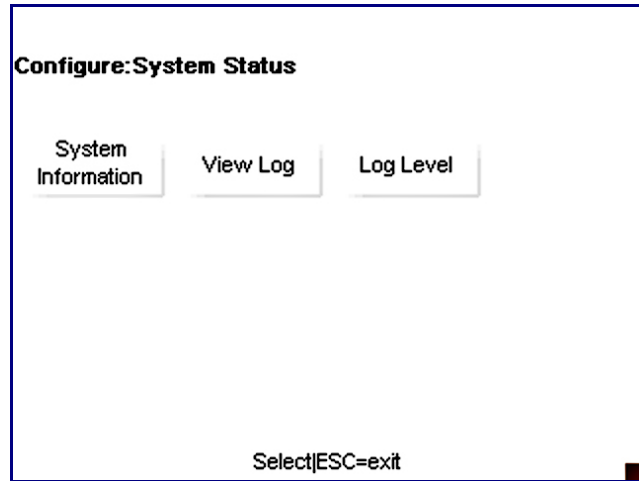

System Information – brings up a list of current system versions and addresses

View Log – array gives user access to the various log lists

Log Level – allows user to choose between “**Low**,” “**Mid**” and “**High**” in regards to how comprehensive the log function is

System Information

The **System Information** window is a read-only screen that displays various versions and addresses for the unit.

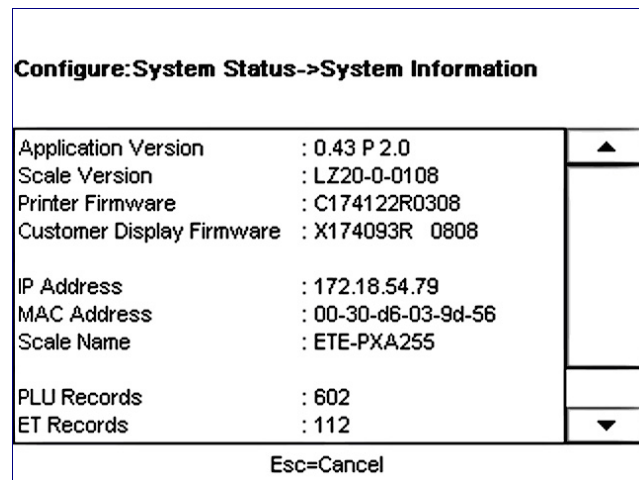

Log View

This section allows the viewing of logged data. Touch your selection – **Event** or **Error** – edit the filter parameters and press **Display Log**.

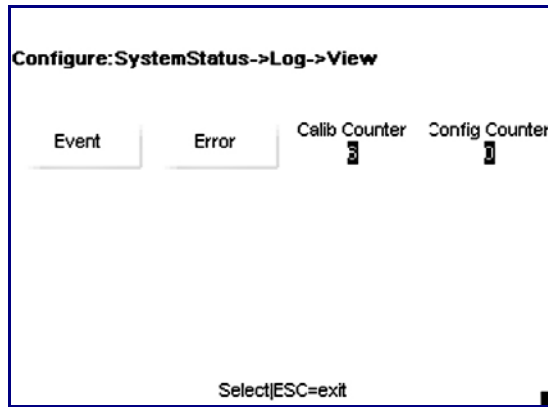

View Event Log – this menu displays a comprehensive list of the actions taken to modify the parameters of the scale. Everything from on-and-off times to when specific PLU display modes were modified can be listed here, assuming you have the **Log Level** set high enough. This scrollable list can be limited by date or specific event type.

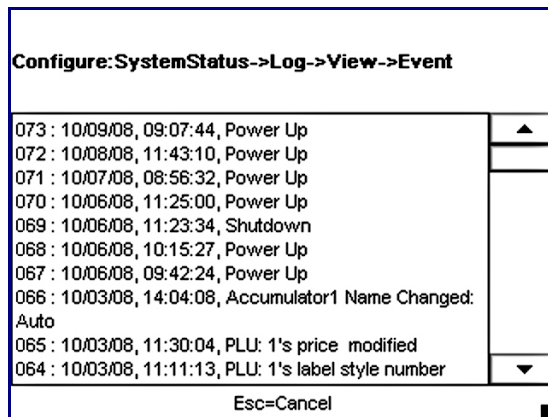

View Error Log – this menu displays any and all errors that have occurred within the timeframe you choose.

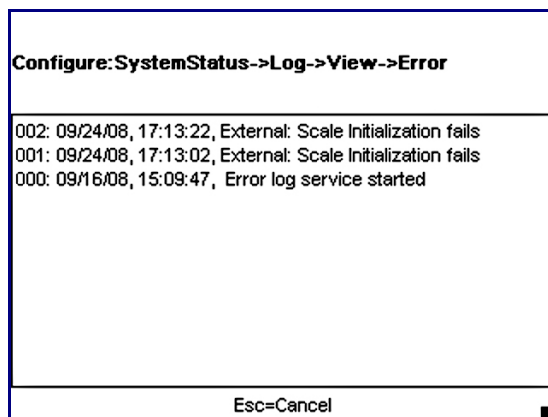

Calibration and Configuration Counter – these read-only fields represent the following:

Calibration Counter – represents the number of times the load cell has been calibrated.

Configuration Counter – tallies the number of times a weights and measures parameter edit has been performed by a technician. The number of edits performed at any one time does not matter – an edit performed under any single technician menu area is considered a single edit.

Log Level

The **Log Level** menu allows the user to select how comprehensive the log function is.

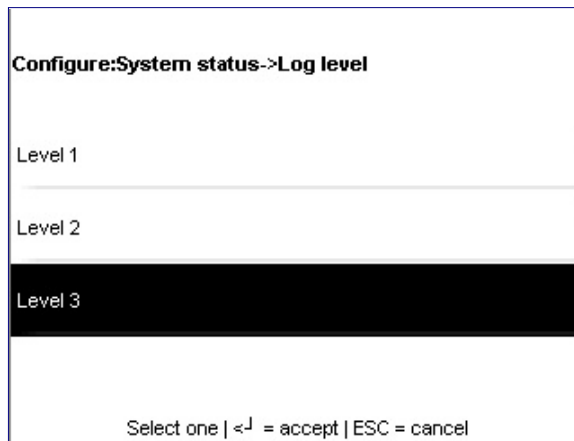

Touch to select a particular level and press the **Enter** key.

Marquee

The **Marquee** function allows creating a slideshow of images and text that will show on the customer display. Images can be imported into the Impact S from a USB drive.

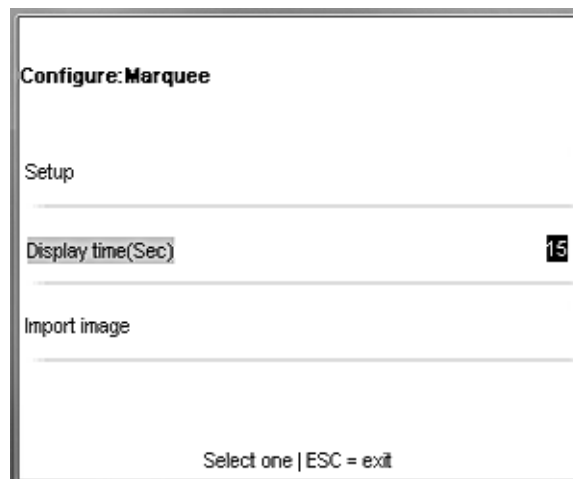

Setup – Select the graphics that will appear in the marquee as well as their order.

Display Time (sec) – Set the duration, in seconds, for which the marquee images will display before changing.

Import Image – Import a new graphic from an external USB drive or from the Impact images folder.

Setup

Setup is used to select the images to display and also the order in which they will appear on the customer display.

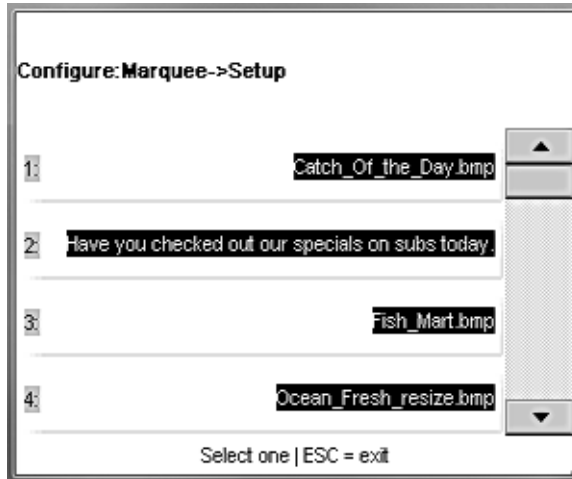

Touch the line to add or edit. If there is an existing image, the menu gives the option to change it (Edit), Swap positions, or Delete.

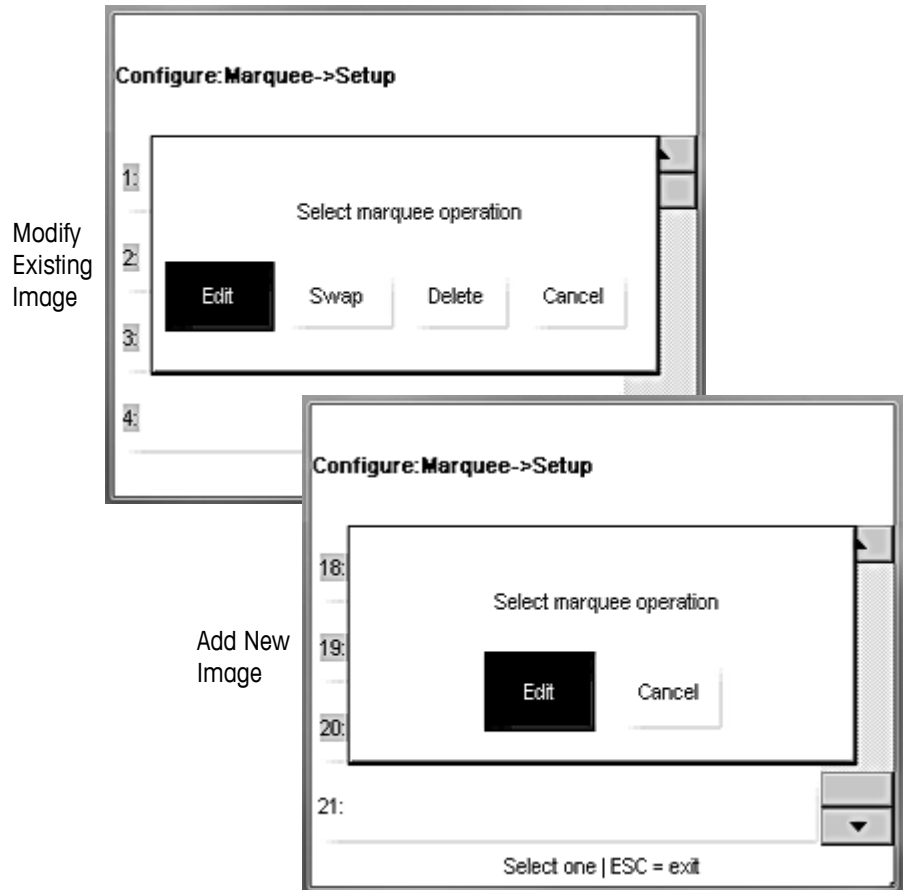

Import Image

The **Import Image** menu is used to copy new images into the Impact-S database.

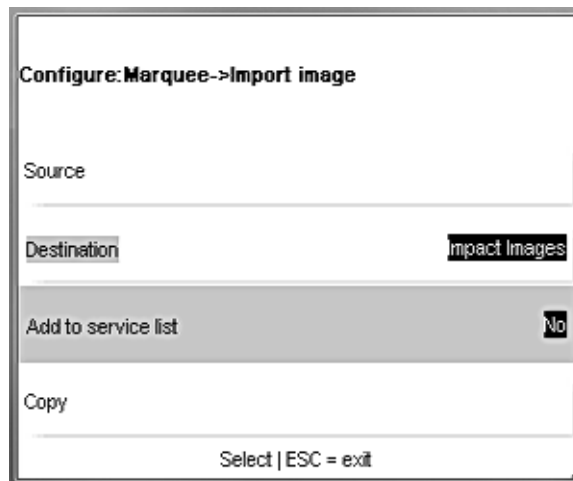

Imported images **MUST MEET** the following requirements to properly display on the Impact S customer display screen:

- 1.) .BMP file format. It helps to open and re-save these in Microsoft Paint before importing them, as many other programs use compression algorithms that are not properly decoded by the Impact S software
- 2.) Black and white. The files must be converted to grayscale/black and white or they will not display properly.
- 3.) Dimensions of 240 pixels wide by 189 pixels high.

The images can be imported from the Impact S images folder or a USB drive. First select the source drive and then the file.

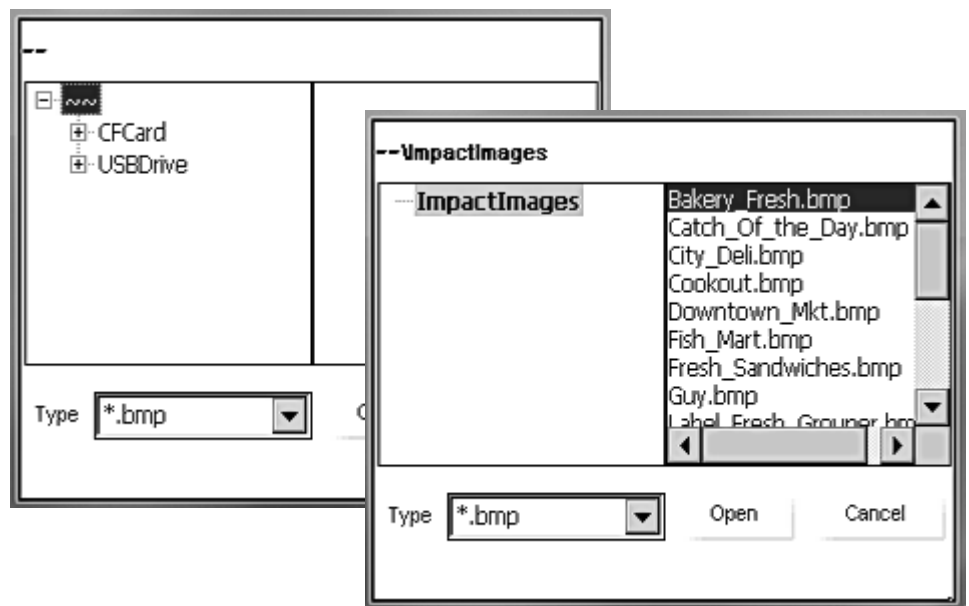

Touch the Copy button to complete the file copy.

Timer

Enter the time (in seconds) to display each marquee image. The default is 15 and the valid range is 0 (off) and up to 99 seconds.

The screenshot shows a terminal window titled "Configure: Marquee". Inside the window, there is a menu structure with "S" on the left and "D" on the right. The "D" option is selected, and its sub-menu is displayed, showing "Display time(Sec)" with a value of "15" in a text box. At the bottom of the window, it says "Select one | ESC = exit".

4

Labels

Loading Labels

When changing a label roll, always look for any label glue or dust buildup and clean if needed. See Chapter 5 for details.

Open the printer door and using the green tab, pull the printer from the housing. Unlock and raise the printhead by pulling up on the latch.

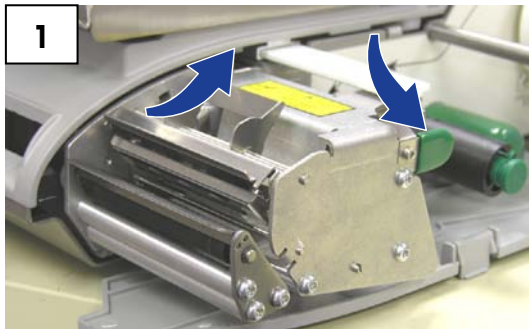

Install the label roll on the supply spool and slide the labels underneath the printer and on top of the platen roller and out the front.



For stripped label mode, remove about 6 inches of labels from the liner. For un-stripped mode, close the printhead.

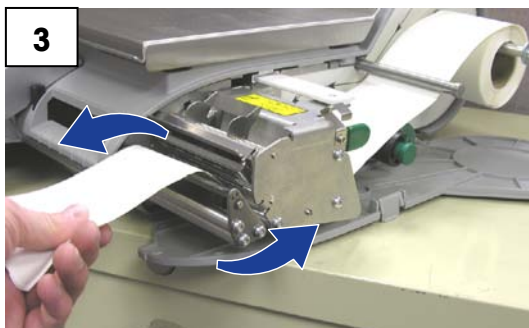

Push in on the green knob to lock the liner into place, and then turn the roller clockwise to take up the slack in the liner. To unlock the liner, pull out gently on the knob. NOTE: The green knob does not come all the way out! Do not use excessive force to pull out on the green knob.



Press down on the printhead latch until it locks down. Push the printer back in and close the door.

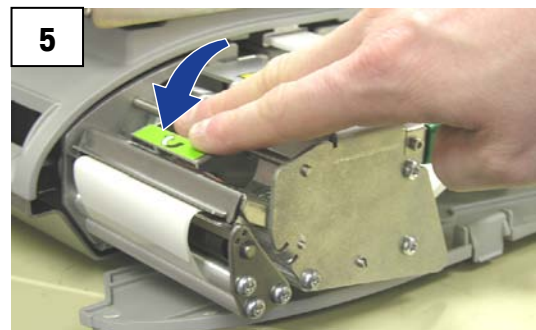

6

Press the Print button () to feed the labels ensuring they will stage correctly.

When first loading labels or changing label sizes, press the **CONFIG Button** (), **Printer Setup, Label Group**. Select the label size installed in the printer. If unsure, use Measure Label to automatically determine the length.

Label Requirements

The purpose of this section is to specify the requirements of thermal labels to be used in Mettler Toledo retail scale and pre-pack thermal printers.

This document includes dimensional requirements for labels and label rolls, as well as general requirements for label paper, thermal coatings, preprinting inks and adhesives. Use of label materials and designs which meet with these requirements is necessary to ensure operation of the printers in compliance with their respective functional specifications and satisfactory performance of the label in the end-use environment. Labels which do not comply with all of the requirements of this document may function with limitations, but would need to be tested by the customer to insure adequate performance in their application. Customer specified (COD) software is not covered under this specification.

Label Paper

DESCRIPTION, PRICE LABEL: Premium white color, black imaging, with protective coating

DESCRIPTION, DAY-GLO LABEL: Red orange fluorescent, black imaging, with protective coating

WEIGHT: 72 ± 7 grams/square meter

THICKNESS: 82 ± 14 μ meter (0.0032 inch)

Activation Temperature

STANDARD: Initial 74°C (165°F); Optimum 83°C (181°F)

HIGH SPEED: Initial 66°C (151°F); Optimum 77°C (170°F) – for highest speed printing

HOT BOX: Initial 83°C (181°F); Optimum 91°C (195°F) - for use on food items which are kept warm

SURFACE SMOOTHNESS: The surface of the finished coated paper must be smooth to prevent premature printhead failure. Smoothness must be 40 Sheffield units or smoother.

ION CONTENT: Ions such as sodium (Na) and chlorine (Cl) can cause premature failure of the glass overcoat of a thermal printhead. Paper manufactured specifically for thermal printing with low ion content must be used.

STORAGE LIFE: 18 months minimum when stored at less than 85% relative humidity and less than 35°C (95°F).

Adhesive

Permanent pressure sensitive – Nominal thickness 10 μ meter (0.0004 inch)

Label must adhere to product with a surface temperature of -15° C (5° F) minimum.

Bond strength must remain permanent over a temperature range of 2°C to 35°C (35°F to 95° F).

Release Liner

DESCRIPTION: White semi-bleached supercalendered Kraft paper with silicone release coating

BASIS WEIGHT: 68 ± 3 gram/square meter

THICKNESS: 67 ± 7 μ METER (0.0026 INCH)

Total Thickness (LABEL + ADHESIVE + LINER)

159 ± 17 μ METER (0.0056 to 0.0069 inch)

Light transmission for Gap Sensor Operation

(see optical density definition)

Light transmission at a wavelength of 800 to 900 NM through the liner **ONLY** must be at least three times the transmission through the liner and label together. This means that the transmission optical density of the liner must be at least 0.48 less than the that of the liner and label together

Light transmission at 800 to 900 NM wave length through the liner and label together must be at least 2% of incident light. This corresponds to an optical density of 1.7.

Label Stripping

Labels must strip from the liner over a temperature range of 2°C (26°F) at 50% RH to 43°C (110°F) at 85% RH.

Finished Label Roll Requirements

Core and Method of Label Attachment

The label stock must **not** be permanently attached to the cardboard core. The liner must separate cleanly from the core with 1.0 pound pull tangent to the core as shown in Figure 1. No core material, tape, or adhesive is to remain on the label or liner after separation. Material, especially hot-melt adhesive, remaining on the label can damage the printhead.

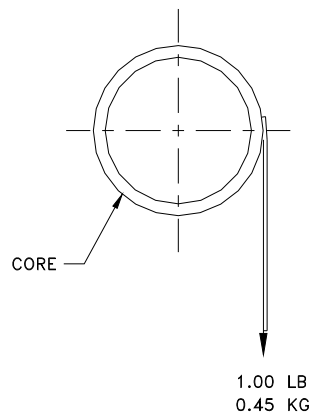

Die Cutting

Die cutting of the labels must not perforate the release liner.

Slitting

The release liner must be slit cleanly and be made free of edge slivers and dust by vacuuming or some equally effective process.

Winding

The labels must be wound face out as shown in Figure 2. The finished roll must be made free of paper dust and loose particles by vacuuming or some equally effective process.

Label; Curl

Stripped labels must not curl more than 0.020 inch as specified in the figure below.

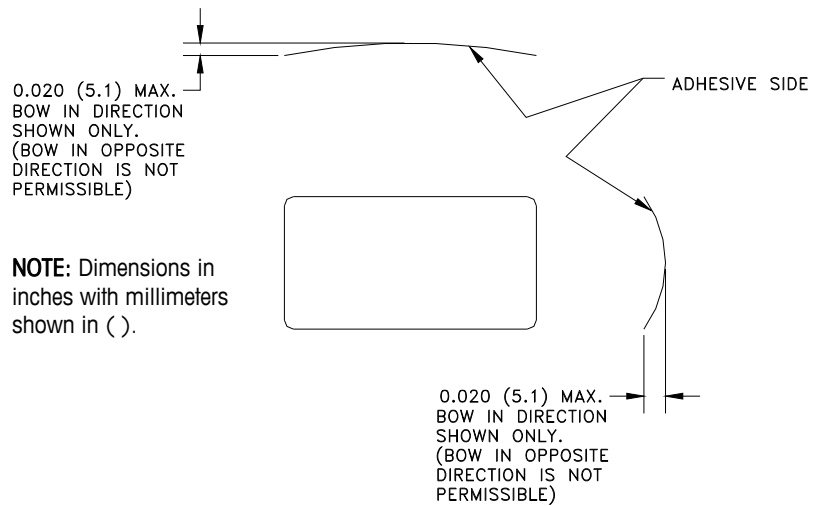
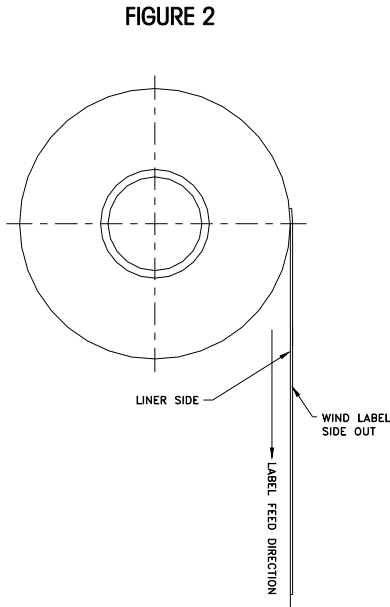

NOTE: Dimensions in inches with millimeters shown in ().

Splicing

Each roll may contain one splice on non-label side of liner using 0.002 inch maximum thickness tape as shown below.

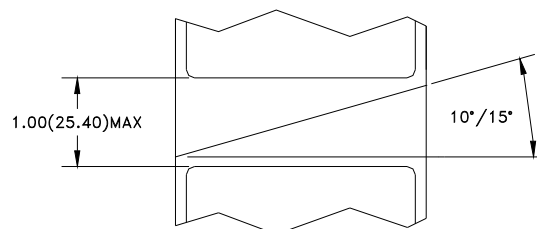

Finished Label and Roll Dimensional Requirements

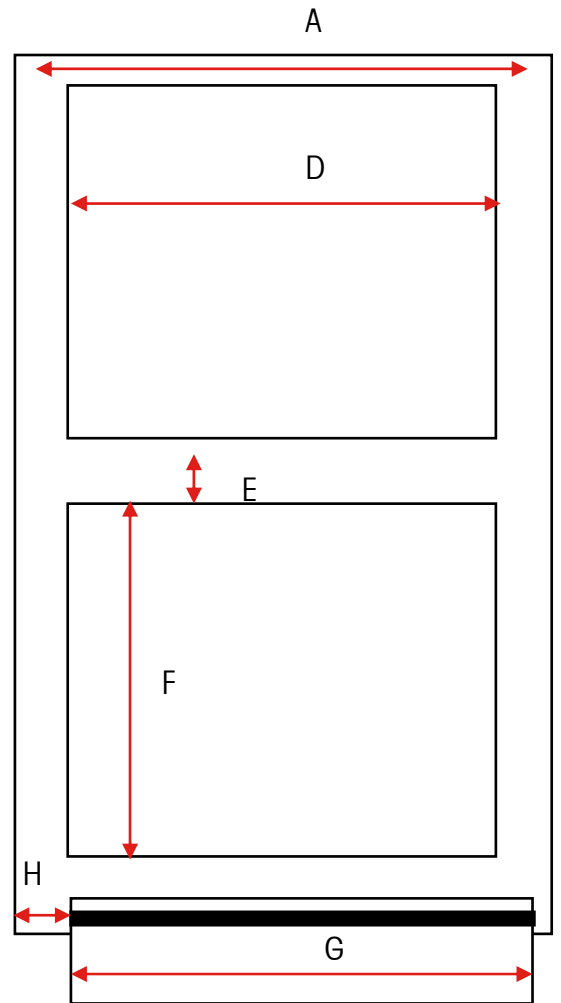
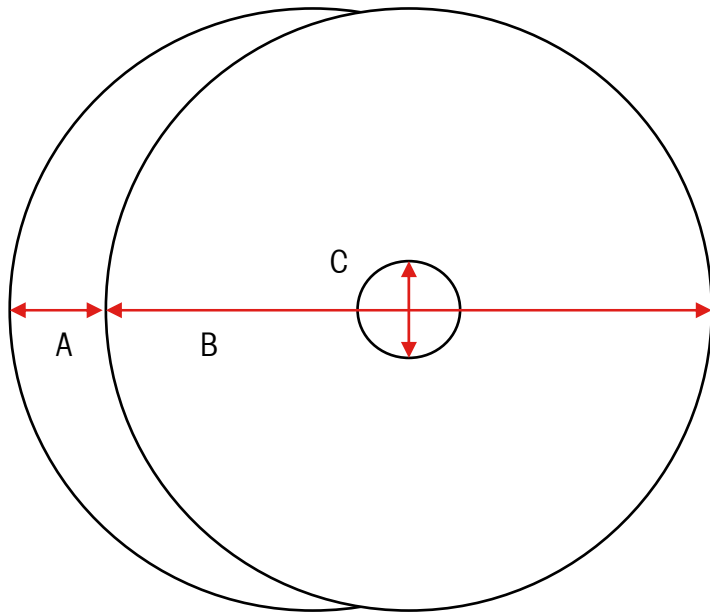

Item	Description	Range	Impact S	
			3"	
			Inches	MM
A	Liner Width	Max	3.346	85
		Min	1.575	40
B	Roll Diameter	Max	6.0	152
C	Core Inside Diameter	Min	1.56	40
D	Label Width	Max	2.635	66.9
		Min	2.615	66.4
E	Gap Width	Min/Max	0.125 +/- .01 inches	
F	Label Length	Max	7.0	177.8
		Min	0.9	23
G	Effective Print Width	Min	2.835	72
H	Left side Offset	Min	0.157	4

Typical Dimensions – 3" Label Roll

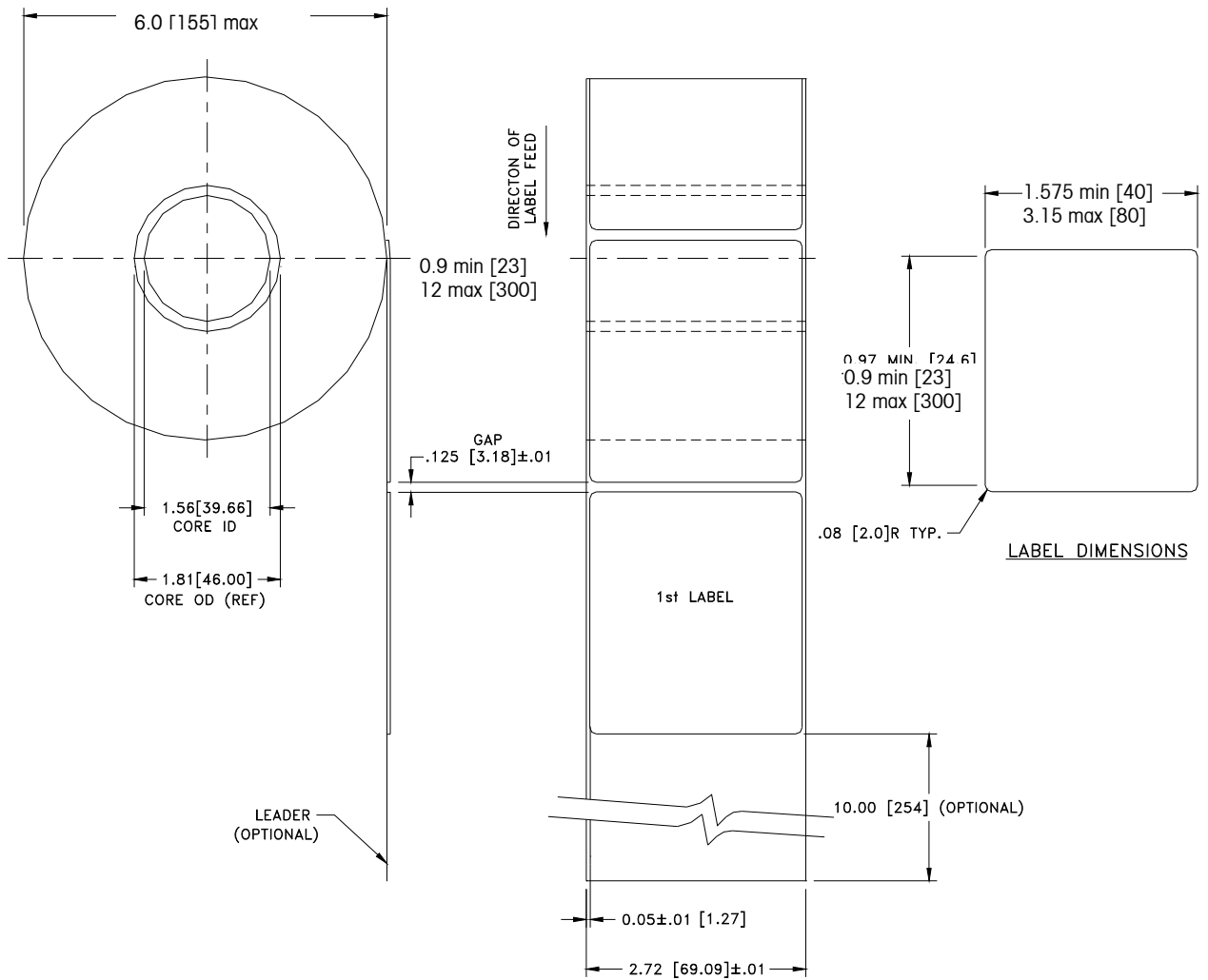

Note: Dimensions in inches with millimeters shown in [].

FINISHED ROLL AND LABEL DETAIL – PRICE LABEL

Preprinted Labels

To ensure trouble free operation of the printer gap sensor, and to achieve normal print head life, no pre printing should be placed on the label in the gap sensor path or in areas which will be printed by the scale printer. See Figure 7. However, since preprinting is commonly used by many customers the following guidelines must be followed.

1. Inks used for preprinting must be specially formulated for use in thermal printers. If proper inks are not used they can adhere to the print head. This ink build up on the print head will interfere with heat transfer from the print head to the paper and cause printing elements to burn out. Another problem with inks not formulated for thermal printing is that they can contain chemicals which will cause the glass overcoat to chip off of the print head, causing failure to print in the chipped areas.
2. If black ink is used in preprinting in the gap sensor path shown in Figure 7, a dense black stripe will have to be printed on the back of the liner, as shown in Figure 8, to prevent the gap sensor from being affected by the black preprinting. (Colors other than black might also be a problem and should be tested by the customer) The black stripe must have gaps which correspond to the label gaps. The black stripe on the liner must have a minimum transmission optical density of 2.3 and must be uniform. (see optical density – page 8) In addition, the gap sensor circuit will need to be adjusted for operation with the black stripe as explained in the product service manual. This adjustment will need to be checked any time label paper is changed, for example when labels are procured from a new supplier.
3. If an optical density of at least 2.3 cannot be achieved in the black stripe on the back of the liner, the liner width should be increased (as shown in Figure 9) so that the preprinted label is not in the gap sensor path. For the Impact S, the sensor path in the center of the label must be free of black preprinting.

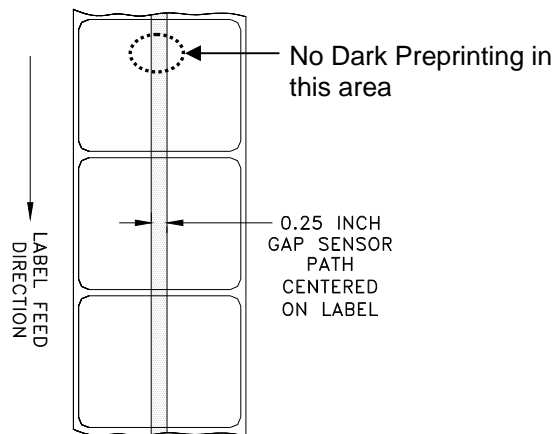
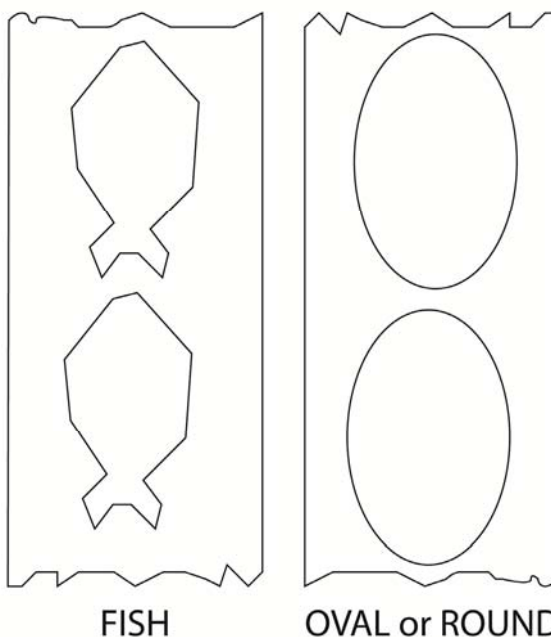

FIGURE 9

Special Shaped Labels

Labels with shapes other than rectangular will cause gap detection errors if the gap dimension (in the gap sensor path) is outside the limits given in this document, or if the edge of the label shape crosses into and out of the sensor path as shown below. For these cases the black stripe will have to be printed on the back of the liner as shown previously. Tests will be needed to determine if the stripe will be adequate or if additional liner width will be required. The safe approach is to use the black stripe configuration shown previously on all odd shaped labels.

Some examples of oddly-shaped labels that will require the black stripe for optical measure.



Optical Densities

Definition of Transmission of Optical Density

Transmission optical density is defined as:

Optical Density = \log_{10} (incident light / transmitted light) = \log_{10} (100 / % light transmission)

Transmission optical density can be measured with a transmission densitometer that meets ANSI standards. Examples are the Macbeth model TD903 and TD932.

Optical density for 100% light transmission = \log_{10} (100/100) = \log_{10} (1) = 0

Optical density for 0.1% light transmission = \log_{10} (100/0.1) = \log_{10} (1000) = 3

Label and Liner Optical Density

If liner paper transmits 2% of the light which is incident on it, the optical density is \log_{10} (100/2) = 1.7

If the light transmitted through the liner is 3 times the light transmitted through the liner and label, the relative optical densities are:

Optical Density of Liner + Label = \log_{10} (100 / X)

Optical Density of Liner Only = \log_{10} (100 / 3X)

= \log_{10} (0.3333X)

= \log_{10} 0.3333 + \log_{10} (X)

= $\log_{10}(X) - 0.48$

Therefore, if the liner must transmit 3 times the light that the liner and label transmits, the transmission optical density of the liner must be 0.48 less than the transmission optical density of the liner and label.

Black Stripe Optical Density

If only 0.5 % of incident light is transmitted through the black stripe, the optical density is:

$$\log_{10} (100 / 0.5) = \log_{10} (200) = 2.3$$

The purpose of specifying a transmission optical density of at least 2.3 for the printed black stripe on the back of the label is to minimize any variation in light transmission as a result of black pre-printing on the front of the label. This variation due to black preprinting can cause the gap sensor to give gap detection errors.

METTLER TOLEDO

For your notes

5



Maintenance

External Cleaning

Open the printer door by pressing down on the release tab.

- Disconnect Power
- Do not use solvents or commercial cleaners on the unit. They may harm the surfaces or damage the touchscreen.
- Do not spray directly on or at the unit!



	WARNING ELECTRICAL SHOCK HAZARD Disconnect all power to this unit before cleaning or servicing.
	
NOTICE	
PROPERTY DAMAGE Do not spray or wash down. Disconnect all power to this unit before cleaning. Follow the cleaning instructions detailed in the manual.	



- Touchscreen, keypad, and customer displays - **Only use a soft clean cloth** dampened with mild detergent and water to clean the operator display and customer display screens. Do not scrape with sharp objects.
- Covers and platter – Clean using a soft clean cloth dampened with a mild cleaner or detergent and water.

Printer Cleaning

Clean the printhead anytime you notice the print quality has degraded.

	<p>NOTICE</p> <p>TO PREVENT EQUIPMENT DAMAGE Do not use any metal or sharp object to scrape the printhead or the printer platen roller. This may cause serious equipment damage.</p>
---	--

Lift the latch to release and raise the printhead. Use the **Cleaning Pen** to clean any glue or debris from the black striped area of the printhead. A cotton swab and alcohol may also be used in place of the cleaning pen.

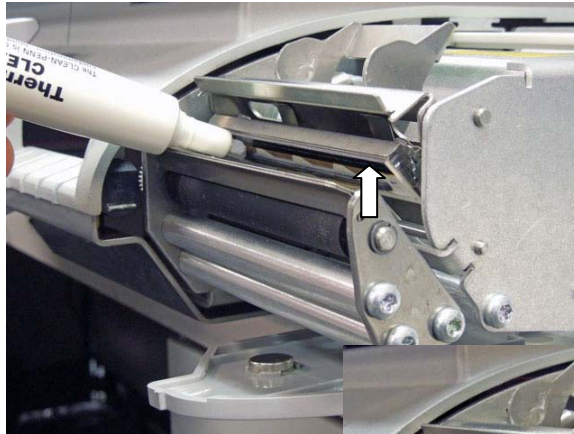

Use a small brush to clean any surfaces with dust or label residue buildup.

Clean the platen roller using a Clean Pen or a swab moistened with alcohol.

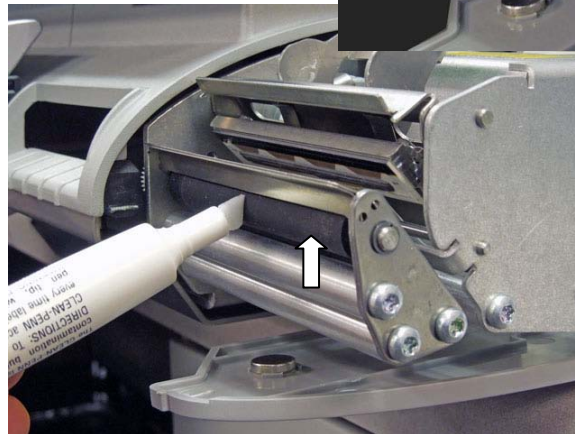

Press the Print button to rotate the roller. Rotate the roller again and repeat the above procedure until the roller is clean.

Note: You may need to thread labels up through the gap sensor to avoid receiving a Low Stock error.

6

Appendix

Geo Index

The scale controller can compensate for variations caused by gravitational forces. The geo index for the location where the scale is calibrated is programmed into the scale controller at the factory. When the scale is moved to a new location, the geo index for the new location should be entered in scale setup. Use the following table to determine the geo index for a location.

METTLER TOLEDO Impact S® User's Guide

Northern and Southern latitude in degrees and minutes	Height above sea level in meters										
	0 325	325 650	650 975	975 1300	1300 1625	1625 1950	1950 2275	2275 2600	2600 2925	2925 3250	3250 3575
	Height above sea level in feet										
	0 1060	1060 2130	2130 3200	3200 4260	4260 5330	5330 6400	6400 7460	7460 8530	8530 9600	9600 10660	10660 11730
0° 0' — 5° 46'	5	4	4	3	3	2	2	1	1	0	0
5° 46' — 9° 52'	5	5	4	4	3	3	2	2	1	1	0
9° 52' — 12° 44'	6	5	5	4	4	3	3	2	2	1	1
12° 44' — 15° 6'	6	6	5	5	4	4	3	3	2	2	1
15° 6' — 17° 10'	7	6	6	5	5	4	4	3	3	2	2
17° 10' — 19° 2'	7	7	6	6	5	5	4	4	3	3	2
19° 2' — 20° 45'	8	7	7	6	6	5	5	4	4	3	3
20° 45' — 22° 22'	8	8	7	7	6	6	5	5	4	4	3
22° 22' — 23° 54'	9	8	8	7	7	6	6	5	5	4	3
23° 54' — 25° 21'	9	9	8	8	7	7	6	6	5	5	4
25° 21' — 26° 45'	10	9	9	8	8	7	7	6	6	5	5
26° 45' — 28° 6'	10	10	9	9	8	8	7	7	6	6	5
28° 6' — 29° 25'	11	10	10	9	9	8	8	7	7	6	6
29° 25' — 30° 41'	11	11	10	10	9	9	8	8	7	7	6
30° 41' — 31° 56'	12	11	11	10	10	9	9	8	8	7	7
31° 56' — 33° 9'	12	12	11	11	10	10	9	9	8	8	7
33° 9' — 34° 21'	13	12	12	11	11	10	10	9	9	8	8
34° 21' — 35° 31'	13	13	12	12	11	11	10	10	9	9	8
35° 31' — 36° 41'	14	13	13	12	12	11	11	10	10	9	9
36° 41' — 37° 50'	14	14	13	13	12	12	11	11	10	10	9
37° 50' — 38° 58'	15	14	14	13	13	12	12	11	11	10	10
38° 58' — 40° 5'	15	15	14	14	13	13	12	12	11	11	10
40° 5' — 41° 12'	16	15	15	14	14	13	13	12	12	11	11
41° 12' — 42° 19'	16	16	15	15	14	14	13	13	12	12	11
42° 19' — 43° 26'	17	16	16	15	15	14	14	13	13	12	12
43° 26' — 44° 32'	17	17	16	16	15	15	14	14	13	13	12
44° 32' — 45° 38'	18	17	17	16	16	15	15	14	14	13	13
45° 38' — 46° 45'	18	18	17	17	16	16	15	15	14	14	13
46° 45' — 47° 51'	19	18	18	17	17	16	16	15	15	14	14
47° 51' — 48° 58'	19	19	18	18	17	17	16	16	15	15	14
48° 58' — 50° 6'	20	19	19	18	18	17	17	16	16	15	15
50° 6' — 51° 13'	20	20	19	19	18	18	17	17	16	16	15
51° 13' — 52° 22'	21	20	20	19	19	18	18	17	17	16	16
52° 22' — 53° 31'	21	21	20	20	19	19	18	18	17	17	16
53° 31' — 54° 41'	22	21	21	20	20	19	19	18	18	17	17
54° 41' — 55° 52'	22	22	21	21	20	20	19	19	18	18	17
55° 52' — 57° 4'	23	22	22	21	21	20	20	19	19	18	18
57° 4' — 58° 17'	23	23	22	22	21	21	20	20	19	19	18
58° 17' — 59° 32'	24	23	23	22	22	21	21	20	20	19	19
59° 32' — 60° 49'	24	24	23	23	22	22	21	21	20	20	19
60° 49' — 62° 9'	25	24	24	23	23	22	22	21	21	20	20
62° 9' — 63° 30'	25	25	24	24	23	23	22	22	21	21	20
63° 30' — 64° 55'	26	25	25	24	24	23	23	22	22	21	21
64° 55' — 66° 24'	26	26	25	25	24	24	23	23	22	22	21
66° 24' — 67° 57'	27	26	26	25	25	24	24	23	23	22	22
67° 57' — 69° 35'	27	27	26	26	25	25	24	24	23	23	22
69° 35' — 71° 21'	28	27	27	26	26	25	25	24	24	23	23
71° 21' — 73° 16'	28	28	27	27	26	26	25	25	24	24	23
73° 16' — 75° 24'	29	28	28	27	27	26	26	25	25	24	24
75° 24' — 77° 52'	29	29	28	28	27	27	26	26	25	25	24
77° 52' — 80° 56'	30	29	29	28	28	27	27	26	26	25	25
80° 56' — 85° 45'	30	30	29	29	28	28	27	27	26	26	25
85° 45' — 90° 00'	31	30	30	29	29	28	28	27	27	26	26

Country Currency Defaults

Country	Symbol	Total \$ Format	Cent Separator	Cent Separator
Argentina	\$	5.2	,	comma
Belize	BZ\$	5.2	.	period
Bolivia	\$b	5.2	,	comma
Brazil	R\$	5.2	.	period
Canada English	\$	5.2	.	period
Canada French	\$	5.2	,	comma
Caribbean	\$	5.2	.	period
Chile	\$	5.2	,	comma
Colombia	\$	5.2	,	comma
Costa Rica	₡	5.2	,	comma
Dominican Republic	RD\$	5.2	.	period
Ecuador	\$	5.2	,	comma
El Salvador	\$	5.2	.	period
Guatemala	Q	5.2	.	period
Honduras	L.	5.2	.	period
Jamaica	J\$	5.2	.	period
Mexico	\$	5.2	.	period
Nicaragua	C\$	5.2	.	period
Panama	B/.	5.2	.	period
Paraguay	Gs	5.2	,	comma
Peru	S/.	5.2	.	period
Puerto Rico	\$	5.2	.	period
Trinidad & Tobago	TT\$	5.2	.	period
Uruguay	\$U	5.2	,	comma
US Virgin Islands	\$	5.2	.	period
USA	\$	5.2	.	period
Venezuela	Bs	5.2	,	comma

Country Time Defaults

Country	Default Time	Time Format	Default Display Date	Default Print Date
Argentina	24 hr	hh:mm:ss	DD/MM/YY	DD/MM/YYYY
Belize	12 hr	hh:mm:ss	DD/MM/YY	DD/MM/YYYY
Bolivia	12 hr	hh:mm:ss	DD/MM/YY	DD/MM/YYYY
Brazil	12 hr	hh:mm:ss	DD/MM/YY	DD/MM/YYYY
Canada English	24 hr	hh:mm:ss	DD/MM/YY	DD/MM/YYYY
Canada French	24 hr	hh:mm:ss	YY/MM/DD	YYYY/MM/DD
Caribbean	12 hr	hh:mm:ss	MM/DD/YY	MM/DD/YYYY
Chile	24 hr	hh:mm:ss	DD/MM/YY	DD/MM/YYYY
Colombia	12 hr	hh:mm:ss	DD/MM/YY	DD/MM/YYYY
Costa Rica	12 hr	hh:mm:ss	DD/MM/YY	DD/MM/YYYY
Dominican Republic	12 hr	hh:mm:ss	DD/MM/YY	DD/MM/YYYY
Ecuador	24 hr	hh:mm:ss	DD/MM/YY	DD/MM/YYYY
El Salvador	12 hr	hh:mm:ss	DD/MM/YY	DD/MM/YYYY
Guatemala	12 hr	hh:mm:ss	DD/MM/YY	DD/MM/YYYY
Honduras	12 hr	hh:mm:ss	DD/MM/YY	DD/MM/YYYY
Jamaica	12 hr	hh:mm:ss	DD/MM/YY	DD/MM/YYYY
Mexico	12 hr	hh:mm:ss	DD/MM/YY	DD/MM/YYYY
Nicaragua	12 hr	hh:mm:ss	DD/MM/YY	DD/MM/YYYY
Panama	12 hr	hh:mm:ss	DD/MM/YY	DD/MM/YYYY
Paraguay	12 hr	hh:mm:ss	DD/MM/YY	DD/MM/YYYY
Peru	12 hr	hh:mm:ss	DD/MM/YY	DD/MM/YYYY
Puerto Rico	12 hr	hh:mm:ss	DD/MM/YY	DD/MM/YYYY
Trinidad & Tobago	12 hr	hh:mm:ss	DD/MM/YY	DD/MM/YYYY
Uruguay	12 hr	hh:mm:ss	DD/MM/YY	DD/MM/YYYY
US Virgin Islands	12 hr	hh:mm:ss	MM/DD/YY	MM/DD/YYYY
USA	12 hr	hh:mm:ss	MM/DD/YY	MM/DD/YYYY
Venezuela	12 hr	hh:mm:ss	DD/MM/YY	DD/MM/YYYY

Misc. Country Defaults

Country	Retail Default Wt	Accuracy	Default Lang
Argentina	kg	Single	ESP
Belize	kg	Single	EN
Bolivia	kg	Single	ESP
Canada English	kg	Single	EN
Canada French	kg	multi	FR
Caribbean	kg	Single	EN
Chile	kg	Single	ESP
Colombia	kg	Single	ESP
Costa Rica	kg	Single	ESP
Dominican Republic	lb	Single	ESP
Ecuador	kg	Single	ESP
El Salvador	lb	Single	ESP
Guatemala	lb	Single	ESP
Honduras	lb	Single	ESP
Jamaica	kg	Single	EN
Mexico	kg	Single	ESP
Nicaragua	kg	Single	ESP
Panama	kg	Single	ESP
Paraguay	kg	Single	ESP
Peru	kg	Single	ESP
Puerto Rico	lb	Single	ESP
Trinidad & Tobago	kg	Single	EN
Uruguay	kg	Single	ESP
US Virgin Islands	lb	Single	EN
USA	lb	Single	EN
Venezuela	kg	Single	ESP

METTLER TOLEDO

For your notes



METTLER TOLEDO Service



Quality Management System certification.

Development, production, and auditing in accordance with ISO9001. Environmental management system in accordance with ISO14001.

Worldwide service. Our dense service network, among the best in the world, ensures the maximum availability and lifespan of your product.

Conformité Européene - This label is your guarantee that our products conform to the latest guidelines.

On the Internet. You can find important information about our products and services, as well as our company, quickly and easily at <http://www.mt.com/support>



METTLER TOLEDO

1900 Polaris Parkway
Columbus, Ohio 43240
www.mt.com

P/N: 64065336

METTLER TOLEDO® and Impact S®
are registered trademarks of Mettler-Toledo, LLC
©2012 Mettler-Toledo, LLC
Printed in USA



64065336